

29 SERIES

INSTALLATION INSTRUCTIONS



WARNING:

- This product must be installed in accordance with the applicable installation code by a person familiar with the construction and operation of the product and the hazards involved.
- Make sure all electrical power is turned off while installing the fixture.
- This luminaire must be adequately grounded for protection against shock hazards and to assure proper operation.
- Disconnect power before servicing.
- LEDs are ESD (Electro Static Discharge) sensitive devices that can be easily damaged if the proper ESD mitigating steps are not taken.
- LEDs are very sensitive to mechanical damage. Caution must be taken to avoid damage to the LEDs.
- ESD or mechanical damage voids all warranties.
- Suitable for dry and damp locations.

STEP 1: Remove the lower lens from the fixture by depressing the lens inward toward the lamp approximately 3/8" at location (A). Then slide the lens toward the same end, releasing it from the end plate at the opposite end of the fixture.

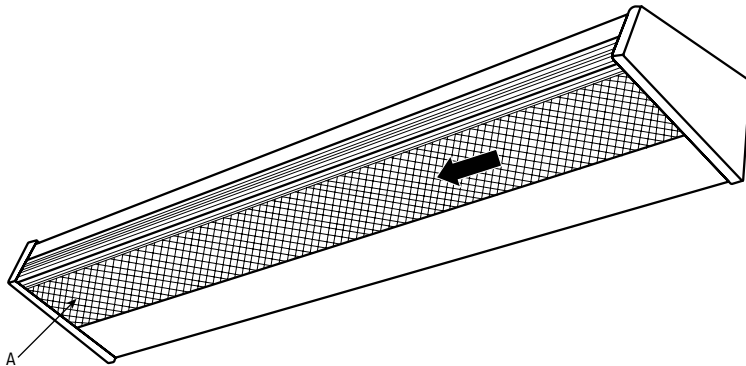

STEP 2: Remove the wireway by removing (2) screws with 1/4" nut driver.

STEP 3: Locate the driver supply wires and knock out the appropriate K.O. for power entry. Power entry hole must be located directly in-line with supply leads from the wall.

STEP 4: Mount the fixture to the wall with appropriate fasteners for the wall surface, using the keyholes as indicated by the illustration and chart shown below:

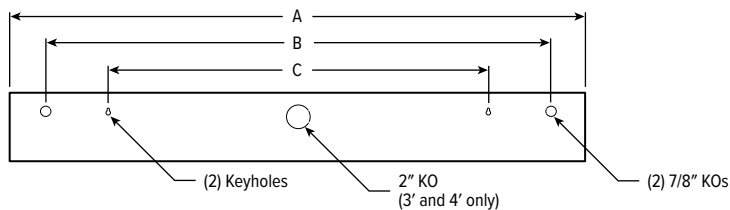

T5/T8

	A	B	C
2'	24-5/8"	19"	16"
3'	36-5/8"	29"	32"
4'	48-5/8"	42-1/2"	32"

LED

	A	B	C
2'	24-5/8"	19-1/8"	16-1/8"
3'	36-5/8"	31-7/8"	29-1/8"
4'	48-5/8"	42"	32"

STEP 5: Complete electrical connections in accordance with local codes.

FIG 5.1

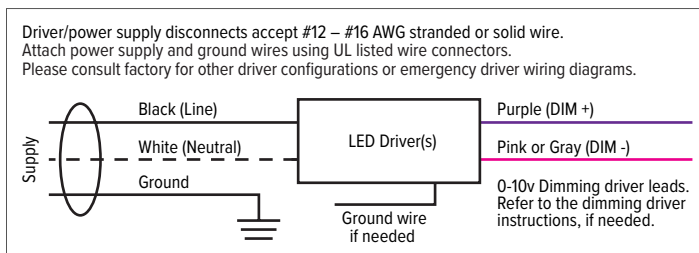

STEP 6: Replace the wireway and lens by reversing steps 2 and 1.