

# VF STRAIGHT ARM VERTICAL TENON

## INSTALLATION INSTRUCTIONS



### WARNING:

- This product must be installed in accordance with the applicable installation code by a person familiar with the construction and operation of the product and the hazards involved.
- Make sure all electrical power is turned off while installing the fixture.
- This luminaire must be adequately grounded for protection against shock hazards and to assure proper operation.
- Disconnect power before servicing.
- LEDs are ESD (Electro Static Discharge) sensitive devices that can be easily damaged if the proper ESD mitigating steps are not taken.
- LEDs are very sensitive to mechanical damage. Caution must be taken to avoid damage to the LEDs.
- ESD or mechanical damage voids all warranties.

### TOOLS/FASTENERS REQUIRED:

- Torque Wrench with range of 15-125 lb-in.

**VF1**  
1/8" Hex Key

**VF2**  
1/8" Hex Key  
5/32" Hex Key

### FOR USE WITH:

- VF1-VT
- VF2-VT

## VERTICAL TENON INSTALLATION

### FOR VERTICAL MOUNTING ONLY.

**STEP 1:** Remove tenon cap by loosening (do not remove) (4) 1/4-20 set screws.

**STEP 2:** Feed incoming power supply wires through the slip fitter and place slip fitter over any 2" (2-3/8 O.D.) tenon.

**NOTE:** Optional slip fitters available from factory to fit over 2-7/8" O.D. or 3" O.D. pole tops.

**STEP 3:** Level top of slip fitter and tighten the (4) 3/8-16 set screws. Torque to 115-125 lb.-in.

**NOTE:** To prevent slip fitter rotation, remove one set screw, drill a small recessed screw point into the tenon or pole, being careful to avoid damaging the threads in the slip fitter. Replace the set screw ensuring proper torque.

**STEP 4:** Replace the tenon cap over supply wires and tighten the (4) 1/4-20 set screws. Torque to 60-70 lb.-in.

**STEP 5:** Make field wiring connections to the fixture and carefully feed the connections inside the slip fitter as you slip the fixture mounting arm over the tenon cap, making sure not to pinch the wires. Tighten the (4) 1/4-20 (VF1) or 3/8-16 (VF2) set screws. Torque to 45-55 lb.-in.(VF1) or 115-125 lb.- in. (VF2). lb.-in.

**STEP 6:** Refer to [VF INSTRUCTIONS](#) for fixture mounting.

**FIG 6.1** Square shown. Round typical.

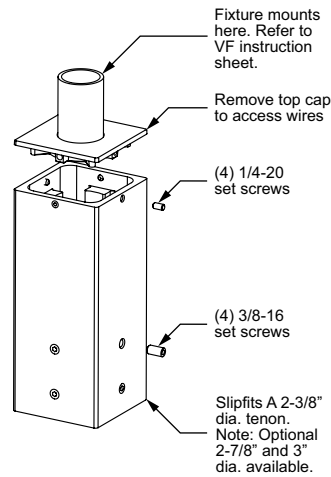

**FIG 6.2** VT-SQ VT-RD

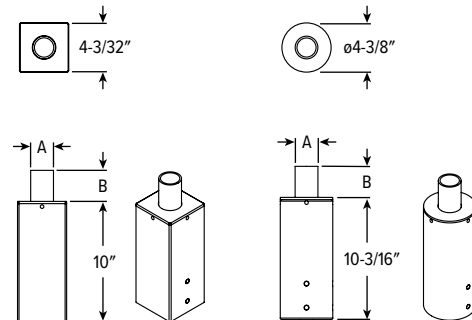

		A	B
VF1	VT-SQ	1-15/16"	2-11/16"
	VT-RD		
VF2	VT-SQ	2-3/8"	4-1/4"
	VT-RD		