

PTS LED SERIES

INSTALLATION INSTRUCTIONS



WARNING:

- Caution - Risk of Shock. This product must be installed in accordance with the applicable installation code by a person familiar with the construction and operation of the product and the hazards involved.
- Make sure all electrical power is turned off while installing the fixture.
- This luminaire must be adequately grounded for protection against shock hazards and to assure proper operation.
- Disconnect power before servicing.
- LEDs are ESD (Electro Static Discharge) sensitive devices that can be easily damaged if the proper ESD mitigating steps are not taken.
- LEDs are very sensitive to mechanical damage. Caution must be taken to avoid damage to the LEDs.
- ESD or mechanical damage voids all warranties.
- Suitable for dry and damp locations. Suitable for dry locations when specified with FieldSELECT™.

BACKVIEWS

1x4

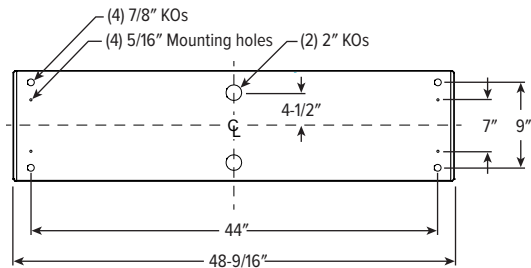

2x2 | 2x4

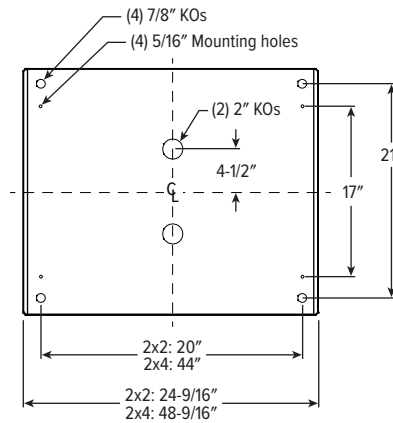

STEP 1: Remove diffuser and reflectors.

STEP 2: Attach fixture(s) to structure using (4) 1/4-20 screws in the mounting holes provided.

STEP 3: Attach power supply and ground wires using UL listed wire connectors. Ballast disconnect accepts #12 - #16 AWG stranded or solid wire.

FIG 3.1

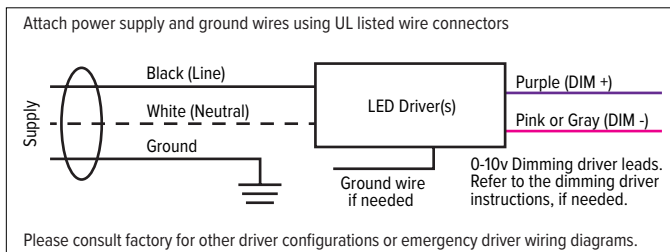

NOTE: Please consult factory for other driver configurations or emergency driver wiring diagrams.

STEP 4: Re-install reflector(s) into housing and install diffuser.

NOTE: Refer to individual product specification sheets for further information.

FieldSELECT

Set CCT selector switch prior to installing fixture.

FIG 4.1

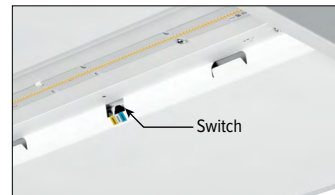

NOTE: De-energize before switching CCT. Failure to do so may damage the LEDs which will void the warranty.