

CB LED SERIES

INSTALLATION INSTRUCTIONS



WARNING:

- This product must be installed in accordance with the applicable installation code by a person familiar with the construction and operation of the product and the hazards involved.
- Make sure all electrical power is turned off while installing the fixture.
- This luminaire must be adequately grounded for protection against shock hazards and to assure proper operation.
- Disconnect power before servicing.
- LEDs are ESD (Electro Static Discharge) sensitive devices that can be easily damaged if the proper ESD mitigating steps are not taken.
- LEDs are very sensitive to mechanical damage. Caution must be taken to avoid damage to the LEDs.
- ESD or mechanical damage voids all warranties.
- Suitable for dry and damp locations.

TABLE OF CONTENTS

INSTALLATION.....	1	TYPICAL WIRING DIAGRAM.....	3
WIRING DESIGNATIONS.....	2		

INSTALLATION

NOTE: CB must be mounted to 4"x 2" horizontal junction box. All other junction boxes will be exposed after installation.

STEP 1: Remove fixture from carton and inspect.

STEP 2: Remove housing cover by pulling to release spring loaded latches.

FIG 2.1

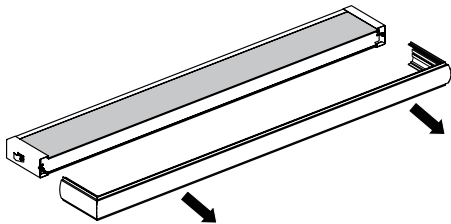

STEP 3: Slide to remove lenses from top and bottom of fixture.

FIG 3.1 Top of Fixture

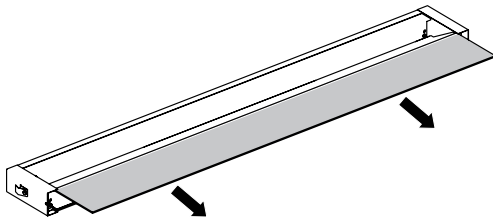
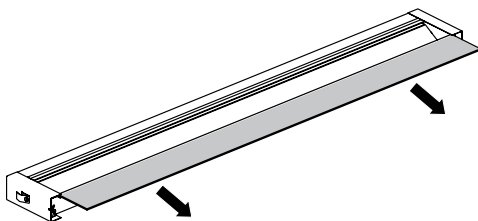
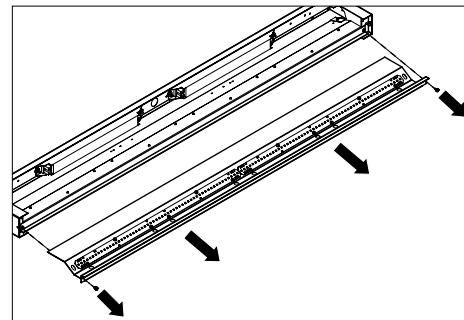

FIG 3.2 Bottom of Fixture



STEP 4: Remove (2) screws from wireway cover. Slide wireway cover to remove. Driver/power supply disconnects will have to be disconnected to remove wireway cover completely.

FIG 4.1



STEP 5: Remove (2) screws from reflector. Remove reflector.

FIG 5.1

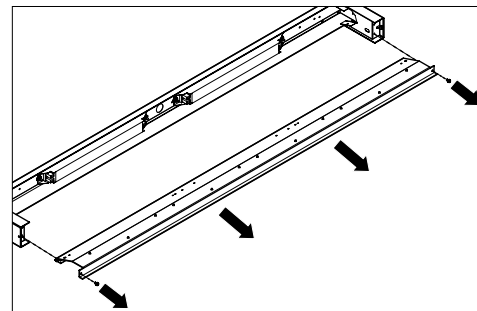

CONTINUED ON PAGE 2

CB LED SERIES

INSTALLATION INSTRUCTIONS

STEP 6: CB must be mounted to 4"x2" horizontal junction box. All other junction boxes will be exposed after installation. Feed power supply wires through $\phi 7/8"$ hole in back channel. Secure fixture to wall using holes provided (hardware by others).

NOTE: Hardware must be adequate to support the weight of the fixture: approximately 14 lbs.

FIG 6.1

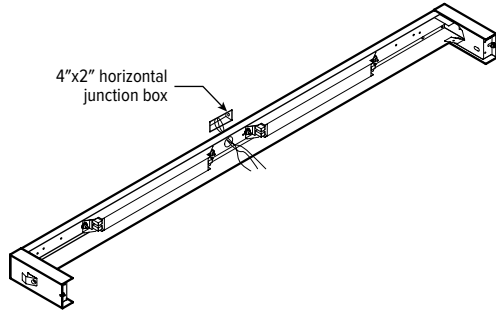

STEP 7: Make electrical connections in accordance with state and local codes. See "TYPICAL WIRING DIAGRAM" on page 3.

STEP 8: Re-install reflector, wireway cover, lenses, and housing cover. Reconnect driver/power supply disconnects when installing reflector and wireway cover.

WIRING DESIGNATIONS

LINE VOLTAGE WIRING

- Low Voltage Relay Supply (unswitched line voltage supply)
- Exam
- Nurse Light
- Ambient
- Reading
- Emergency (unswitched line volt supply)
- Green - Ground
- White - Common for all line voltage supply leads.

Line voltage supply wires for each appropriate lighting aperture. (These are power supply wires which are not being controlled through a low voltage controller inside the fixture and that require switching external to the fixture.)

LINE VOLTAGE

Connect 'Low Voltage Commons' with each of the 'Low Voltage' wires as labeled below using a dry contact, normally open switch.

- Low Voltage Common
- Low Voltage Uplight
- Low Voltage Downlight
- Low Voltage Nurse

Fixture may not be equipped with all of these low voltage functions.

LOW-VOLTAGE CONTROLLER

EXAMPLE: LVC2U/D				
CONTROLLER	LOAD 1		LOAD 2	LOAD 3
LVC1 1-circuit	U D N	Up Down Nurse		
LVC2 2-circuit	U/ D/	Up Down	D/ N/	Down Nurse
LVC3 Dimming control	DIMU/ DIMD/	Uplight, 0-10 dimming ¹ Downlight, 0-10 dimming ¹	U/ D/ N/	Up Down Nurse
	DIMU/DIMD/ Uplight and downlight, 0-10 dimming ¹			N Nurse

120V or 277V only.

¹ Smooth dimming of the load utilizing a single, dry contact, momentary, normally open switch which will dim from 25% up to 100% while holding down the switch.

CB LED SERIES

INSTALLATION INSTRUCTIONS

TYPICAL WIRING DIAGRAM

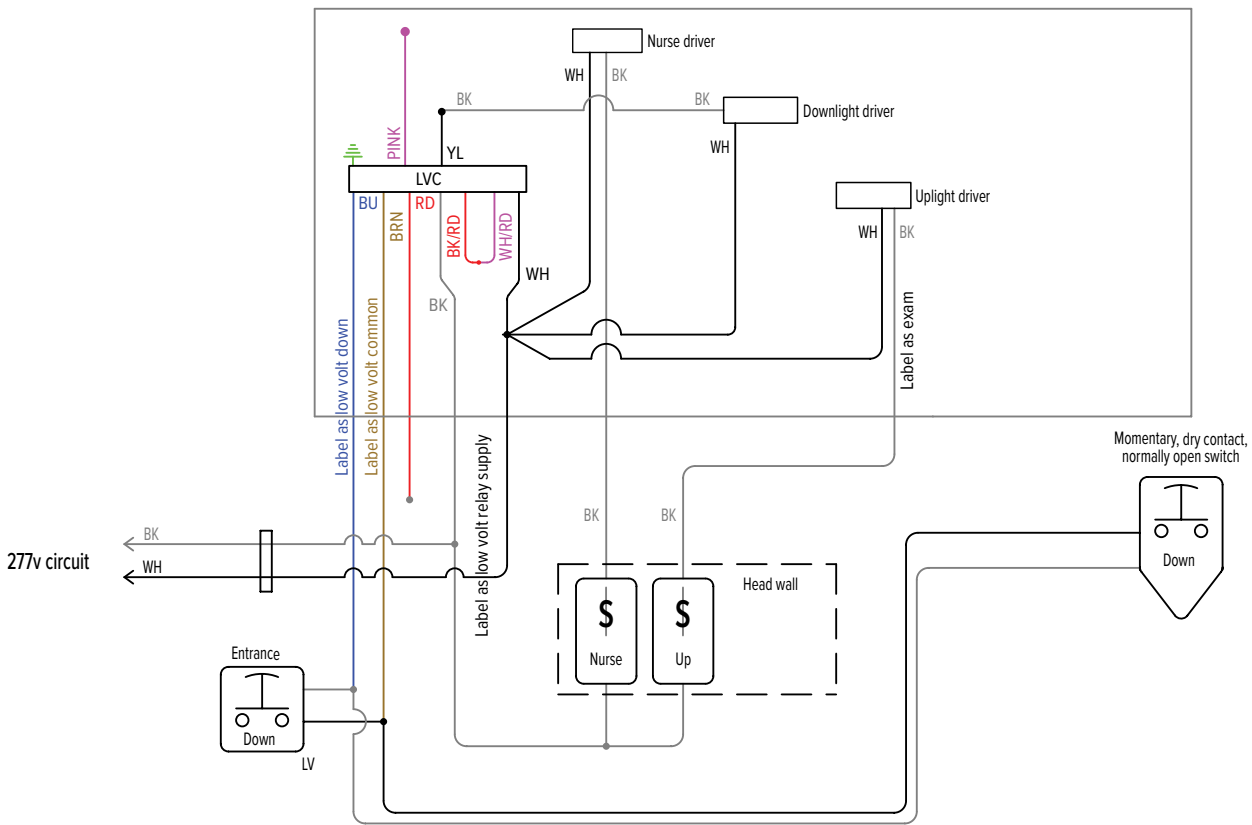

WIRING DIAGRAM DEPICTS:

- Remote switch for control of down lighting.
- Entry (wall) switching of down lighting.
- Line voltage head wall switching of up & nurse lighting.