

DI LED SERIES

INSTALLATION INSTRUCTIONS



WARNING:

- This product must be installed in accordance with the applicable installation code by a person familiar with the construction and operation of the product and the hazards involved.
- Make sure all electrical power is turned off while installing the fixture.
- This luminaire must be adequately grounded for protection against shock hazards and to assure proper operation.
- Disconnect power before servicing.
- LEDs are ESD (Electro Static Discharge) sensitive devices that can be easily damaged if the proper ESD mitigating steps are not taken.
- LEDs are very sensitive to mechanical damage. Caution must be taken to avoid damage to the LEDs.
- ESD or mechanical damage voids all warranties.
- Suitable for dry and damp locations.

TABLE OF CONTENTS

WHAT IS A NEMA "G" (GRID) FIXTURE?.....	1	ACRYLIC DIFFUSER INSTALLATION.....	2
NEMA TYPE "G" INSTALLATION.....	1	WIRING DIAGRAM.....	2

WHAT IS A NEMA "G" (GRID) FIXTURE?

All Williams grid fixtures (NEMA Type "G") are designed to fit securely into a standard NEMA Type "G", 1" nominal T-bar system.

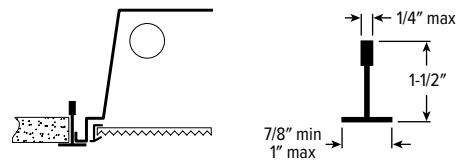

NEMA TYPE "G" INSTALLATION

STEP 1: Follow the steps below to install the fixture(s) into a NEMA Type "G" ceiling system:

- Raise the fixture through the ceiling opening and rest the fixture in the grid system.

FIG 1.A.1

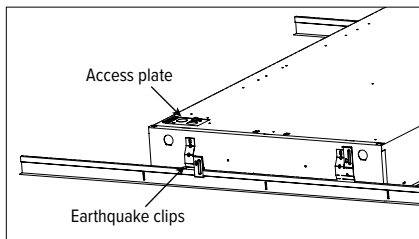

- Center the fixture within the opening.
- If required, use earthquake clips to secure the fixture to the ceiling structure for added stability.
- Refer to local codes for other installation requirements.

STEP 2: Once the fixture is installed into the ceiling system, follow the steps below to complete necessary electrical connections per NEC and all applicable local electrical codes (See "WIRING DIAGRAM" on page 2):

- Remove access plate on the back of the fixture. (See FIG 1.A.1)
- Remove driver/power supply wires from access plate.
- Make wire connections in accordance with local codes. Ground screw is provided on access plate.
- Replace access plate.

STEP 3: Attach the diffuser by lightly spreading out diffuser at each end to enable attachment over studs provided on either end plate.

NOTE: To remove the reflector, insert a thin blade (FBO) between the reflector and the fixture housing along either side of the fixture, and slide along the edge disconnecting the attachment points. Replace the reflector by raising into position and applying light pressure along the attachment points to snap reflector back into position.

FIG 3.0.1

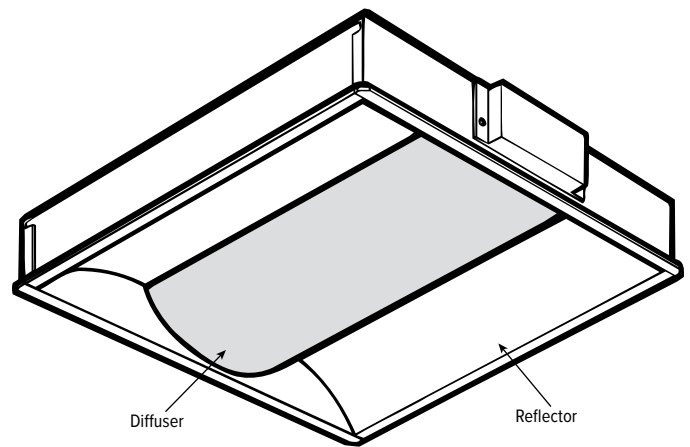

NOTE: Refer to individual product specification sheets for further information.

DI LED SERIES

INSTALLATION INSTRUCTIONS

ACRYLIC DIFFUSER INSTALLATION

STEP 1: The acrylic diffuser is supported by two screws in each fixture endplate. The diffuser can be flexed/spread apart by holding the diffuser with two hands, pushing upward with the thumbs and pulling outward with the fingers (See, FIG 1.1). To secure diffuser to fixture, flex diffuser as stated above while pushing diffuser upward over the outside of the support screws.

FIG 1.1

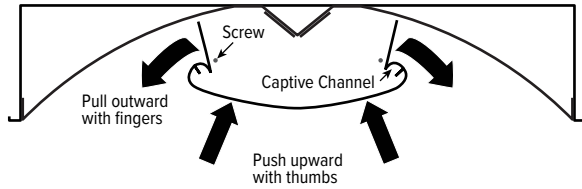

STEP 2: Push the diffuser upward far enough for the captive channel to slide over the top of the screw installed in the fixture endplate. Release the pressure on the diffuser, allowing the diffuser to flex back to its original position and allowing the diffuser to drop down onto the screws installed into the fixture endplate.

STEP 3: Diffuser is shown resting on screws in the final installed position (See, FIG 3.1). The screws are positioned inside the captive channel in the diffuser.

FIG 3.1

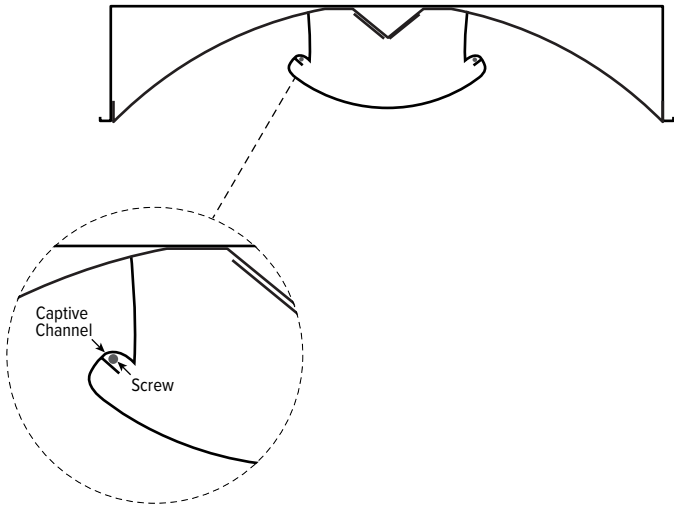

WIRING DIAGRAM

