

WARNING:

- This product must be installed in accordance with the applicable installation code by a person familiar with the construction and operation of the product and the hazards involved.
- Make sure all electrical power is turned off while installing the fixture.
- This luminaire must be adequately grounded for protection against shock hazards and to assure proper operation.
- Disconnect power before servicing.
- LEDs are ESD (Electro Static Discharge) sensitive devices that can be easily damaged if the proper ESD mitigating steps are not taken.
- LEDs are very sensitive to mechanical damage. Caution must be taken to avoid damage to the LEDs.
- ESD or mechanical damage voids all warranties.
- Suitable for dry and damp locations.

TABLE OF CONTENTS

LED BACKVIEWS.....	1	ACRYLIC DIFFUSER INSTALLATION.....	2
FLUORESCENT BACKVIEWS.....	1	WIRING DIAGRAM.....	2
INSTALLATION.....	2		

BACKVIEWS

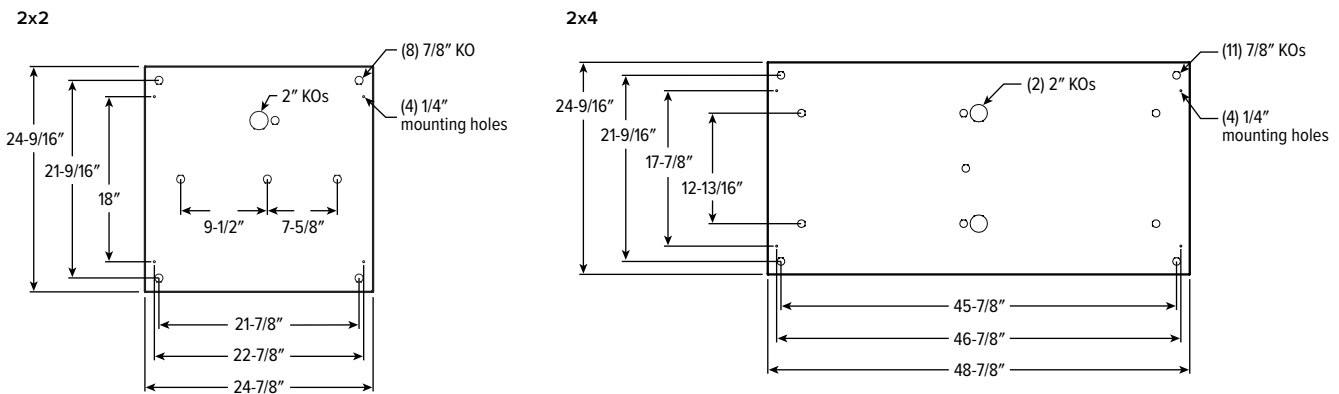

INSTALLATION

STEP 1: Disassemble fixture to expose the internal wiring and knockout.

STEP 2: Remove the center diffuser, if applicable.

FIG 2.1

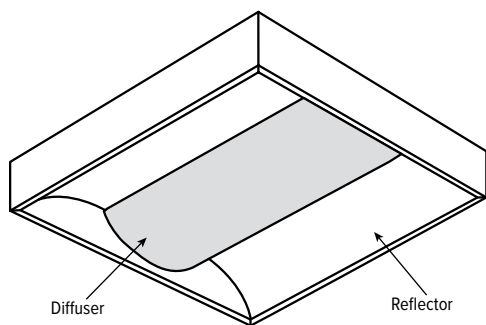

STEP 3: Remove the reflector by inserting a thin blade (by others) between the reflector and the fixture housing along either side of the fixture, and slide along the edge disconnecting the attachment points. Replace the reflector by raising into position and applying light pressure along the attachment points to snap reflector back into position.

STEP 4: With fixture components removed and driver/power supply wiring exposed, remove the 7/8" knockouts in each corner and the 2" center knockout for power entry into the fixture.

STEP 5: Attach the fixture channel to the ceiling structure using bolts and washers or other means (by others) at each corner of the fixture making sure the 2" knockout is centered with the junction box.

NOTE: If other mounting points are needed, the installer can make/drill their own knockout locations.

STEP 6: After the fixture channel is installed and properly supported, make electrical connections inside the fixture housing. Follow any and all applicable city, state, and national electrical codes. See "WIRING DIAGRAM".

STEP 7: Reinstall the reflector pieces into the fixture and wipe off any finger prints.

DIS SERIES

INSTALLATION INSTRUCTIONS

ACRYLIC DIFFUSER INSTALLATION

STEP 1: The acrylic diffuser is supported by two screws in each fixture endplate. The diffuser can be flexed/spread apart by holding the diffuser with two hands, pushing upward with the thumbs and pulling outward with the fingers (See, FIG 1.1). To secure diffuser to fixture, flex diffuser as stated above while pushing diffuser upward over the outside of the support screws.

FIG 1.1

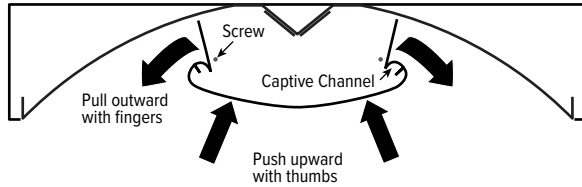

STEP 2: Push the diffuser upward far enough for the captive channel to slide over the top of the screw installed in the fixture endplate. Release the pressure on the diffuser, allowing the diffuser to flex back to its original position and allowing the diffuser to drop down onto the screws installed into the fixture endplate.

STEP 3: Diffuser is shown resting on screws in the final installed position (See, FIG 3.1). The screws are positioned inside the captive channel in the diffuser.

FIG 3.1

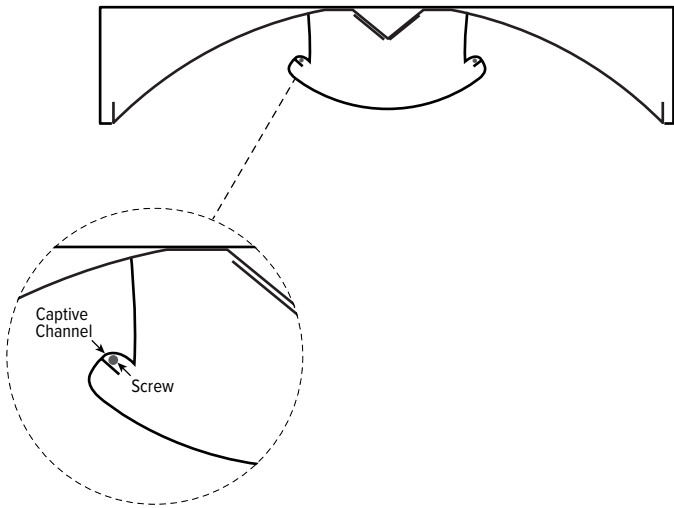

WIRING DIAGRAM

Make electrical connections in accordance with NEC and local codes.

