

INSTALLATION INSTRUCTIONS FOR EMERGENCY EXIT SIGN

IMPORTANT:

When re-lamping, only use lamps specified in the exit sign. Using other lamp types may result in transformer damage or unsafe conditions. Battery in this unit may not be fully charged. After electricity is hooked up to unit, let the battery charge for at least 24 hours. Normal operation of this unit should then take effect (when applicable).



IMPORTANT SAFEGUARDS

When using electrical equipment, basic safety precautions should always be followed including the following:

READ AND FOLLOW ALL SAFETY INSTRUCTIONS

- Do not use outdoors.
- Do not mount near gas or electric heaters.
- Equipment should be mounted in locations and at heights where it will not be subject to tampering by unauthorized personnel.
- The use of accessory equipment not recommended by the manufacturer may cause an unsafe condition.
- Do not use this equipment for other than its intended use.
- Before wiring to power supply, turn off electricity at fuse or circuit breaker.
- Consult local building code for approved wiring and installation.
- Installation and servicing should be performed by qualified personnel.

SAVE THESE INSTRUCTIONS!

Ceiling and End Mount Installation:

1. Connect input as shown in wiring diagram below and fasten canopy to the J-Box bracket.
2. Snap housing to canopy.
3. Connect the battery (when applicable) to the PC Board.
4. Secure faceplate to housing and remove the proper arrow as required.

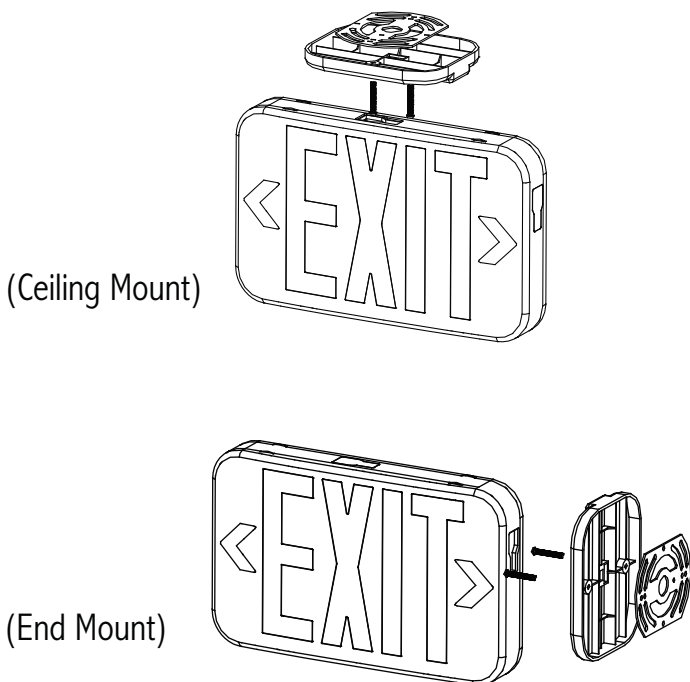

WIRING DIAGRAMS:

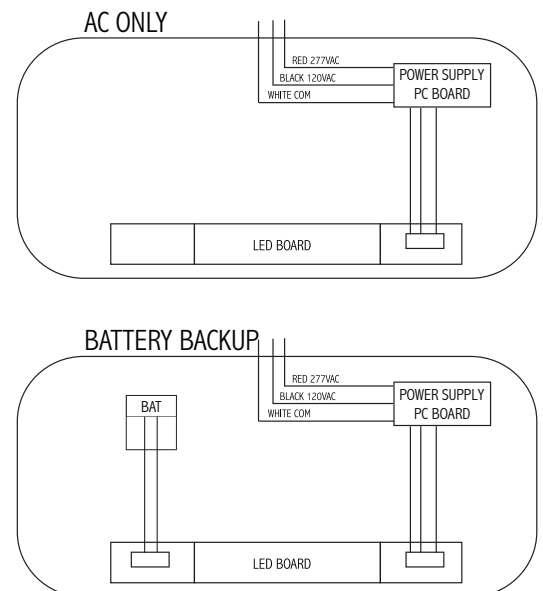

NOTE: Connect to a single source of power supply so that all lamps are simultaneously illuminated.

NOTE: Properly insulate the unused lead with a wire nut or other approved means.

WARNING: Unused wires must be capped using enclosed wire nuts.

INSTALLATION INSTRUCTIONS FOR EMERGENCY EXIT SIGN

OPERATION (Battery Backup):

1. Apply AC power to the unit. The LED Indicator should turn RED.
2. After the battery has been left to charge for 24 hours, test the unit by pushing the switch. The LED indicator turns OFF and the LED board stays ON.
3. When the switch is released, the LEDs turn OFF and the LED indicator turns back to RED.



MAINTENANCE:

Caution: Always turn off AC power to the equipment before servicing. Servicing should be performed only by a qualified service technician. Use only MANUFACTURER supplied replacement parts.

BATTERY: The battery supplied with the Battery Backup model requires no maintenance. However, it should be tested periodically (see TESTING) and replaced when it no longer operates the connected fixtures for the duration of a 30-second or 90-minute test. The battery supplied in this equipment has a life expectancy of 5 years when used in a normal ambient temperature of 72°F.

TESTING:

National Electric Code (NEC) and NFPA life safety code regulations require that routine tests need to be performed as listed below: Once every month, the unit needs to be tested for duration of 30 seconds. Push in and hold the test switch to perform this test. Once every 12 months, a full 90 minute (per UL requirements) test needs to be performed on the unit. Disconnect power to the unit and leave it in the emergency mode. The LEDs should stay ON for at least 90 minutes.