

# GP LED SERIES

## INSTALLATION INSTRUCTIONS



### WARNING:

- Caution - Risk of Shock. This product must be installed in accordance with the applicable installation code by a person familiar with the construction and operation of the product and the hazards involved.
- Make sure all electrical power is turned off while installing the fixture.
- Warning Risk of Electrical Shock - Verify that supply voltage is correct by comparing it with the luminaire label information.
- This luminaire must be adequately grounded for protection against shock hazards and to assure proper operation.
- Disconnect power before servicing.

- Suspend from adequate structure that can safely support the fixture.
- LEDs are ESD (Electro Static Discharge) sensitive devices that can be easily damaged if the proper ESD mitigating steps are not taken.
- LEDs are very sensitive to mechanical damage. Caution must be taken to avoid damage to the LEDs.
- ESD or mechanical damage voids all warranties.
- Suitable for dry and damp locations.

### TABLE OF CONTENTS

HUB MOUNTING .....	1	HOOK & CABLE MOUNTING.....	3
SINGLE POINT HOOK MOUNTING .....	2	GRIPLOCK SYSTEMS GS/Y26/10 MOUNTING.....	4
		SURFACE MOUNT KIT INSTALLATION .....	5

### HUB MOUNTING

#### PARTS INCLUDED WITH 3/4" HUB MOUNTING BOX:

- (1) 3/4" Conduit Lock Nut (LN).
- (1) HUB Mounting Box (MB) (includes 3/4" NPT cast HUB).
- (1) Adjustable 10' aircraft 'Y' cable hanger with toggles (AC).
- (4) Machine Nuts

- STEP 1:** Screw LN onto rigid conduit with locking side of nut facing towards end of conduit to which MB will be attached.
- STEP 2:** Screw 3/4" rigid conduit (FBO) into 3/4" cast HUB in MB until tight.
- STEP 3:** Tighten LN against top of cast HUB to assure MB assembly is locked into position.
- STEP 4:** Remove access plate from MB.
- STEP 5:** Remove access plate from back of fixture and discard. Pull fixture supply leads out through access plate hole.
- STEP 6:** Mount fixture onto MB by guiding mounting bolts (4) through holes in MB. Install all four machine nuts with wrench or nut driver.
- STEP 7:** Make electrical connections of incoming power supply wires from 3/4" rigid conduit to fixture supply wires.
- NOTE:** Wire in accordance with all NEC requirements and any state, city or local electrical codes. See FIG 8.1 on page 1.
- STEP 8:** Replace access plate onto MB.

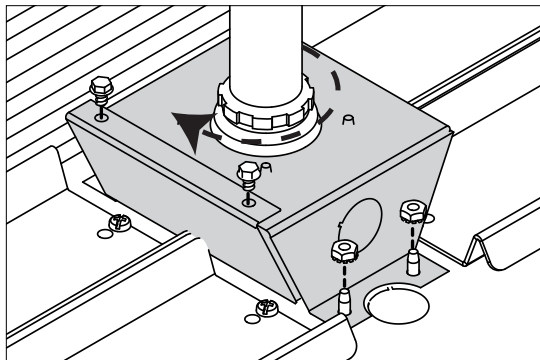
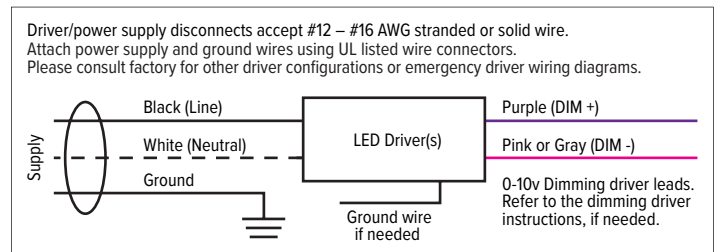

FIG 8.1



#### BALANCING/STABILIZING FIXTURE:

In some cases the fixture will not hang level due to ballast(s) mounting, EM packs, occupancy sensors, air movement, etc., which causes fixture to be unbalanced. If this condition occurs, install the optional AC assembly to level and stabilize the fixture. Attach the two toggles on 'Y' cable through hanging holes on HEAVY end of fixture and attach other end of cable to a building support member using the adjustable gripper on cable. Adjust cable until fixture is level. (Refer to detail for optional methods of attaching leveling cable.)

FIG A

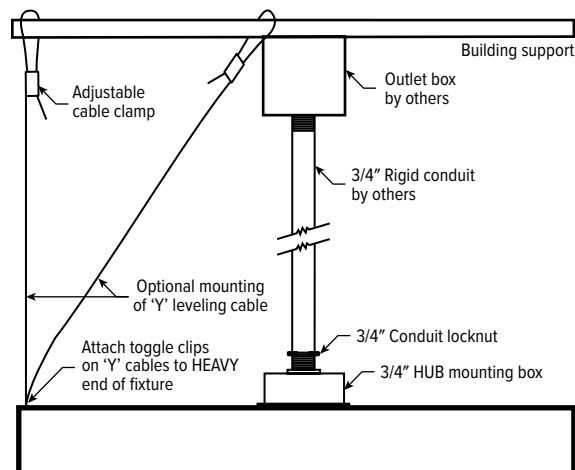

# GP LED SERIES

## INSTALLATION INSTRUCTIONS

### SINGLE POINT HOOK MOUNTING (hook, loop, or eye bolt mount, FBO)

#### PARTS INCLUDED WITH HUB/HOOK MOUNTING BOX:

- (1) 3/4" Conduit Lock Nut (LN).
- (1) 3/4" Cast Fixture Hook (FH).
- (1) HUB Mounting Box (MB) (includes 3/4" NPT cast HUB).
- (1) Adjustable 10' aircraft 'Y' cable hanger with toggles (AC).
- (4) Machine Nuts

**STEP 1:** Screw LN onto FH with locking side of nut facing towards threaded end of FH.

**STEP 2:** Screw FH into cast HUB until tight.

**STEP 3:** Tighten LN against top of cast HUB to assure FH is locked into position.

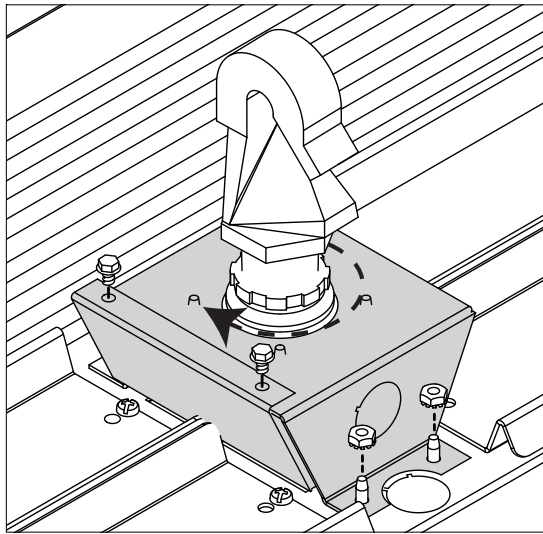

**FIG 3.1**

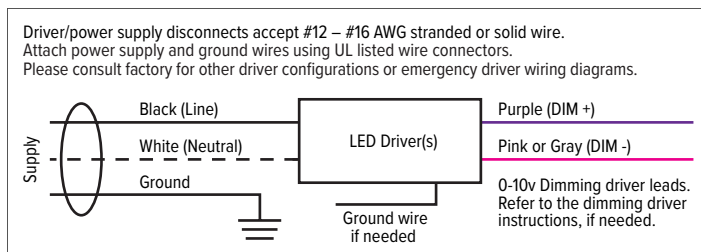

#### BALANCING/STABILIZING FIXTURE:

See FIG A and balancing/stabilizing information on page 1.

**STEP 4:** Remove access plate from back of fixture and discard. Pull fixture supply leads out through access plate hole.

**STEP 5:** Remove access plate from MB.

**STEP 6:** Install MB with FH onto back of fixture by inserting (4) bolts protruding out back of fixture through (4) holes in base of MB. Install all four machine nuts with wrench or nut driver.

**STEP 7:** Lift fixture into position and attach FH onto existing mounting support (FBO).

#### FOR FIXTURES WITH POWER SUPPLY CORD (FBO) OR FLEXIBLE CONDUIT (FBO):

**STEP 8:** Install cord through hole in FH and into MB or if flexible conduit, install in knockout in back of MB using 1/2" electrical fitting of appropriate type.

**STEP 9:** Make electrical connections of incoming power supply cord or flex to fixture supply leads. NOTE: Wire in accordance with all NEC requirements and any state, city or local codes. See FIG 3.1

**STEP 10:** Replace access plate onto MB.

**STEP 11:** If fixture is equipped with a plug, attach plug into receptacle. For fixtures with cord or flex make electrical connections to incoming power supply.

**OR:**

#### FOR FIXTURE WITH FACTORY-ATTACHED POWER SUPPLY CORD IN ACCESS PLATE ON BACK OF FIXTURE:

**STEP 5:** Feed loose end of cord from inside of MB through hole in FH.

**STEP 6:** Install MB with FH onto back of fixture by inserting (4) bolts protruding out back of fixture through (4) holes in base of MB. Install all four machine nuts with wrench or nut driver.

**STEP 7:** Lift fixture into position and attach FH onto existing mounting support (FBO).

**STEP 8:** Make electrical connections from incoming power supply to fixture supply leads (cord). NOTE: Wire in accordance with all NEC requirements and any state, city or local codes. See FIG 3.1

# GP LED SERIES

## INSTALLATION INSTRUCTIONS

### HOOK & CABLE MOUNTING

#### PARTS INCLUDED WITH HOOK AND CABLE KIT:

- (1) 3/4" Cast Fixture Hook with mounting plate.
- (4) Adjustable mounting cables with toggles.

**STEP 1:** Attach hook to eye bolt or loop (FBO) with integral tightening bolt on hook.

**STEP 2:** Loop cables through holes in hook mounting plate, then push one end of the cable through the empty channel of the adjustable cable clamp. Pull the cable until you reach the desired length of cable to use from the hook to the fixture below.

**STEP 3:** Slip the toggles through holes/slots provided in fixture housing. Refer to FIG B for how the fixture should appear when mounted.

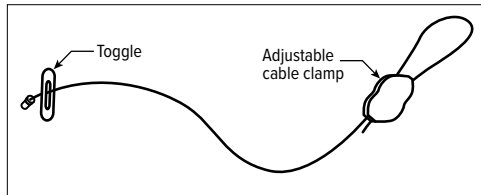
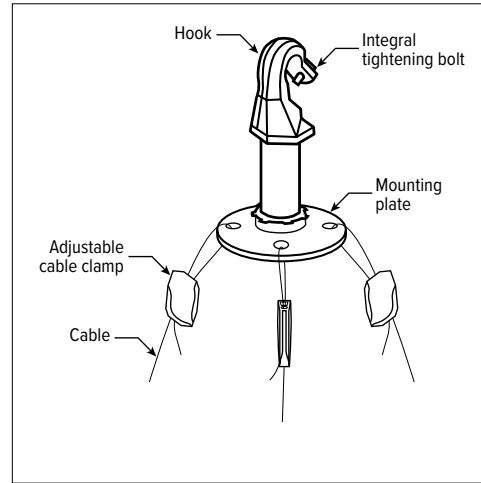

#### BALANCING/STABILIZING FIXTURE:

See FIG A and balancing/stabilizing information on page 1.

FIG B

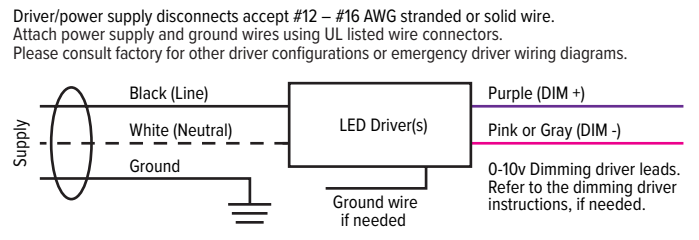
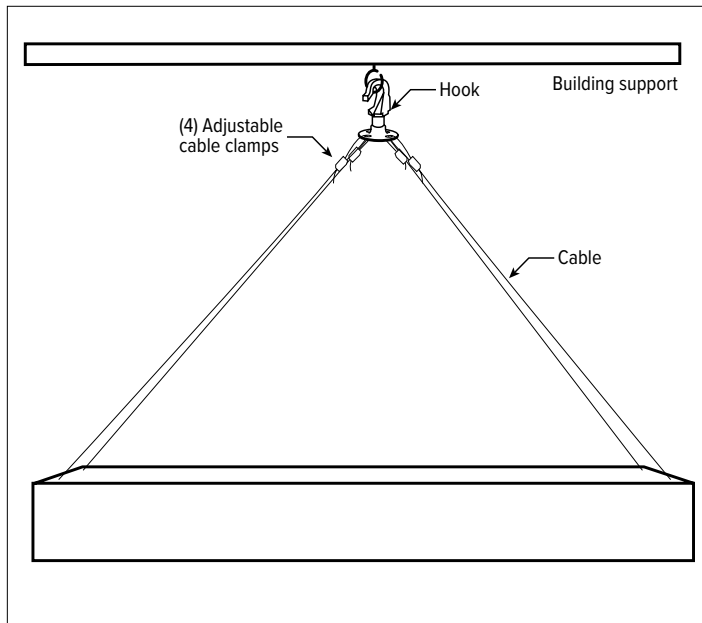

# GP LED SERIES

## INSTALLATION INSTRUCTIONS

### GRIPLOCK SYSTEMS GS/Y26/10 MOUNTING

#### PARTS INCLUDED WITH GRIPLOCK SYSTEM KIT:

- (2) Short cable w/carabiner clips on ends
- (2) Long cable (120") w/looped end
- (2) Gripper assembly

**STEP 1:** Feed long cable over supporting structure/attachment hardware (FBO), passing the straight end of the cable through the looped end to form a lasso around support.

**STEP 2:** Remove knurled screw from the slotted end of the gripper. Install short cable, with carabiner clips on both ends, by inserting into the slot and reinstalling screw.

**STEP 3:** Attach carabiner clips to fixture using the holes provided in the inside end plates of the fixture.

**STEP 4:** Insert the straight end of the long cable into the plunger side of the gripper. The gripper may move freely up the cable but the plunger must be depressed for the gripper to move down the cable. Adjust the fixture to the desired height.

**STEP 5:** Adjust the tilt of the fixture by moving the short cable through the slot and tightening the screw finger **TIGHT**.

**STEP 6:** Repeat steps 1-5 on opposite side of fixture.

**STEP 7:** After all adjustments are made, the long cable may be trimmed so that at least 1" of cable is showing.

Read **INSTALLATION RECOMMENDATIONS** provided in gripper hardware package.

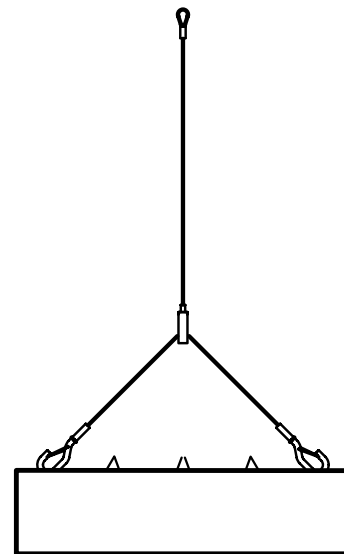
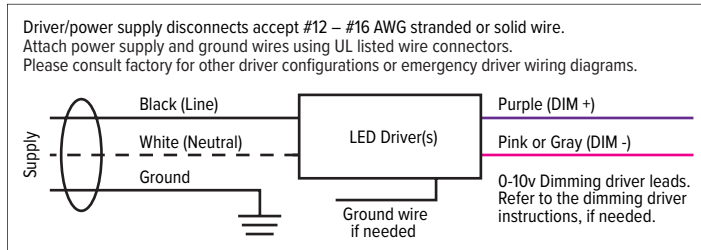
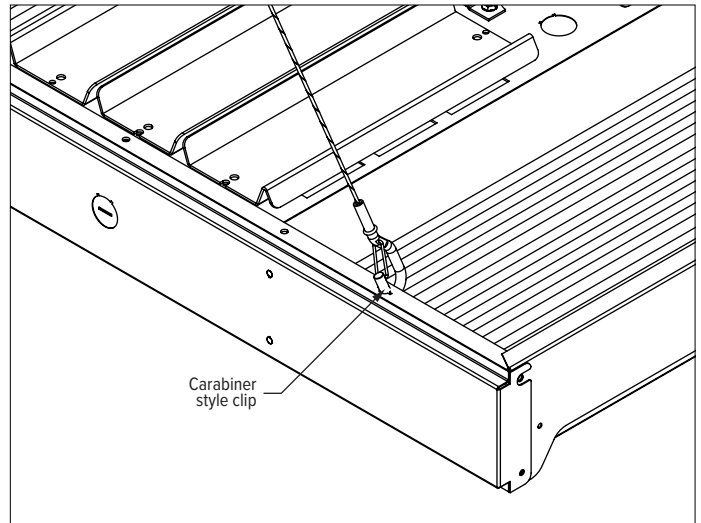

# GP LED SERIES

## INSTALLATION INSTRUCTIONS

### SURFACE MOUNT KIT INSTALLATION

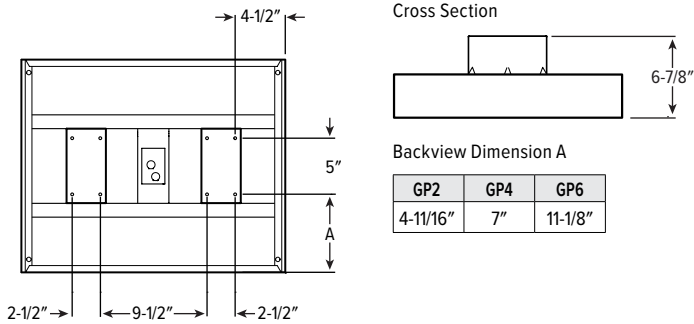

**STEP 1:** Mount (2) SMK brackets to the ceiling surface, carefully aligning both brackets.

**STEP 2:** Raise fixture up, snapping the SMK brackets into the slots on the center driver housing, as shown.

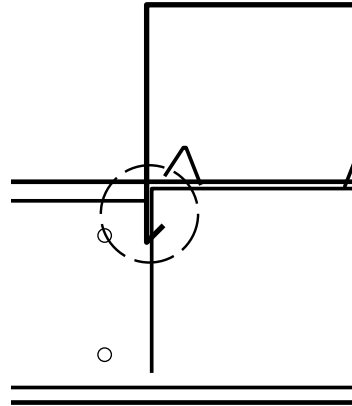
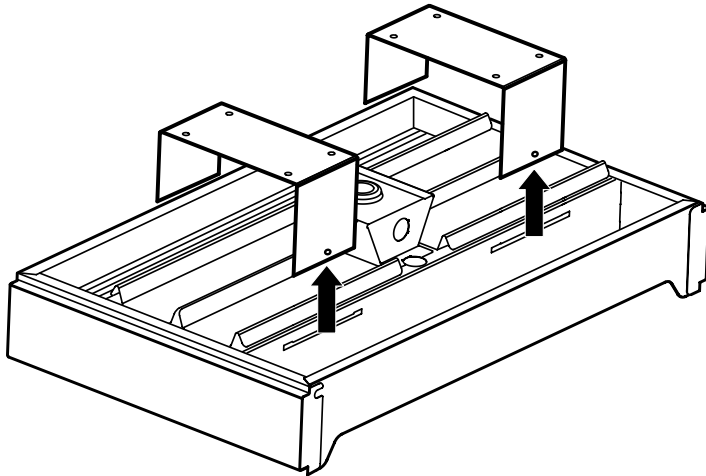

**STEP 3:** Place a screw on each side of the SMK brackets.

