

HIGH BAY INDUSTRIAL

INSTALLATION INSTRUCTIONS



WARNING:

- This product must be installed in accordance with the applicable installation code by a person familiar with the construction and operation of the product and the hazards involved.
- Make sure all electrical power is turned off while installing the fixture.
- This luminaire must be adequately grounded for protection against shock hazards and to assure proper operation.
- Disconnect power before servicing.

- LEDs are ESD (Electro Static Discharge) sensitive devices that can be easily damaged if the proper ESD mitigating steps are not taken.
- LEDs are very sensitive to mechanical damage. Caution must be taken to avoid damage to the LEDs.
- ESD or mechanical damage voids all warranties.
- Suitable for dry and damp locations.

FOR USE WITH:

- GH
- GL
- GLN
- GS
- HL

TABLE OF CONTENTS

A. HUB MOUNTING.....	1	E. GH SMK INSTALLATION.....	4
B. HUB/HOOK MOUNTING	2	F. GS SMK INSTALLATION	5
C. HOOK & CABLE MOUNTING.....	3	G. GS HUB INSTALLATION	6
D. WIRING DIAGRAM.....	3		

A. HUB MOUNTING

PARTS INCLUDED WITH 3/4" HUB MOUNTING BOX:

NOTE: GH 4' fixture requires two hubs for mounting.

- (1) 3/4" Conduit Lock Nut (LN).
- (1) HUB Mounting Box (MB) (includes 3/4" NPT cast HUB).
- (1) Adjustable 10' aircraft 'Y' cable hanger with toggles (AC)

TO INSTALL FIXTURE ONTO 3/4" RIGID CONDUIT (FBO)

FIG A.0.1

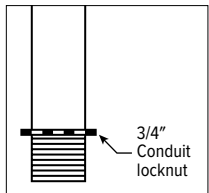
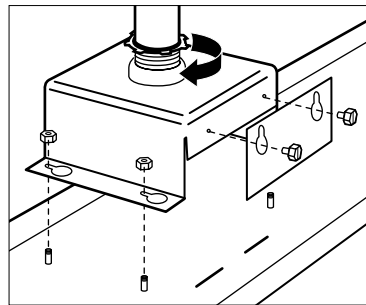

FIG A.0.2



- STEP 1:** Screw LN onto rigid conduit with locking side of nut facing towards end of conduit to which MB will be attached.
- STEP 2:** Screw 3/4" rigid conduit (FBO) to 3/4" cast HUB in MB until tight. NOTE: Access cover plate on MB is to run parallel with length of fixture.
- STEP 3:** Tighten LN against top of cast HUB to assure MB assembly locked into position.
- STEP 4:** Remove wire way access cover from MB.
- STEP 5:** Remove access plate from back of fixture and discard, pull fixture supply leads out through access plate hole.
- STEP 6:** Loosen (4) hex machine nuts approximately 1/8" on bolts protruding out back of fixture housing.

STEP 7: Mount fixture onto MB by lifting fixture and guide (4) mounting bolts with machine nuts through keyholes in MB. (NOTE: Access cover plate should align with two small slots in fixture.) Shift fixture horizontally until all four bolts are positioned in narrow area of keyhole. Tighten all four machine nuts with wrench or nut driver.

STEP 8: Make electrical connections of incoming power supply wires from 3/4" rigid conduit to fixture supply wires. NOTE: Wire in accordance with all NEC requirements and any state, city or local electrical codes. See page 3 for WIRING DIAGRAM.

STEP 9: Replace wire way access cover onto MB.

BALANCING/STABILIZING FIXTURE

In some cases the fixture will not hang level due to ballast(s) mounting, EM packs, occupancy sensors, air movement, etc., which cause the fixture to be unbalanced. If this condition occurs, install the optional AC assembly to level and stabilize the fixture. Attach the two toggles on 'Y' cable through hanging holes on HEAVY end of fixture and attach other end of cable to a building support member using the adjustable gripper on cable. Adjust cable until fixture is level. See FIG A.9.1 for optional methods of attaching leveling cable.

FIG A.9.1

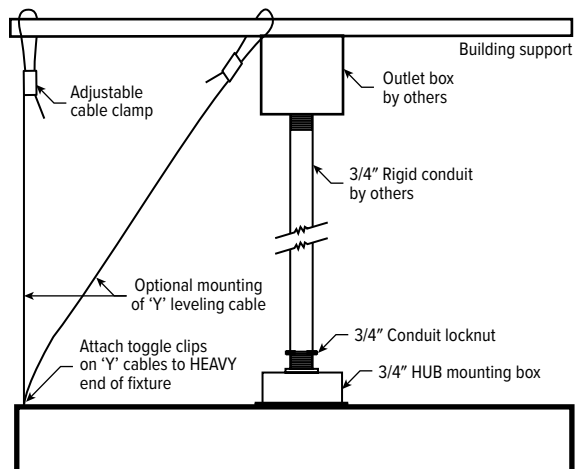

HIGH BAY INDUSTRIAL

INSTALLATION INSTRUCTIONS

B. HUB/HOOK MOUNTING

PARTS INCLUDED WITH HUB/HOOK MOUNTING BOX:

NOTE: GH 4' fixture requires two hooks for mounting.

- (1) 3/4" Conduit Lock Nut (LN).
- (1) 3/4" Cast Fixture Hook (FH).
- (1) HUB Mounting Box (MB) (includes 3/4" NPT cast HUB).
- (1) Adjustable 10' aircraft 'Y' cable hanger with toggles (AC).

TO INSTALL FIXTURE ONTO HOOK, LOOP, OR EYE BOLT MOUNT (FBO)

FIG B.0.1

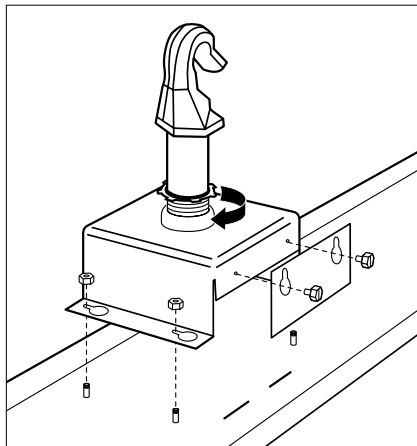

- STEP 1:** Screw LN onto FH with locking side of nut facing towards threaded end of FH.
- STEP 2:** Screw FH into cast HUB until tight. NOTE: Access cover plate on MB is to run parallel with length of fixture, and align with two slots on fixture.
- STEP 3:** Tighten LN against top of cast HUB to assure FH is locked into position.
- STEP 4:** Loosen (4) hex machine nuts approximately 1/8" on bolts protruding out back of fixture housing.

BALANCING/STABILIZING FIXTURE

See page 1 for additional balancing/stabilizing information.

FOR FIXTURES WITH POWER SUPPLY CORD (FBO), FLEXIBLE CONDUIT (FBO) OR CORD AND PLUG (FACTORY FURNISHED)

- Remove access plate from back of fixture and discard. Pull fixture supply leads out through access plate hole.
- Remove wire way access cover from MB.
- Install MB with FH onto back of fixture by inserting (4) bolts/nuts protruding out back of fixture thru (4) keyholes in base of MB. Shift MB horizontally until all four bolts are positioned in narrow part of keyhole. NOTE: Access cover plate on MB is to run parallel with length of fixture, and align with two slots on fixture. Tighten all four machine nuts with wrench or nut driver.
- Lift fixture into position and attach FH onto existing mounting support (FBO).
- Install cord thru hole in FH and into MB or if flexible conduit, install in knockout in back of MB using 1/2" electrical fitting of appropriate type.
- Make electrical connections of incoming power supply cord or flex to fixture supply leads. NOTE: Wire in accordance with all NEC requirements and any state, city or local codes. See page 3 for WIRING DIAGRAM.
- Replace wire way access cover onto MB.
- If fixture is equipped with a plug, attach plug into receptacle. For fixtures with cord or flex make electrical connections to incoming power supply as listed in item F.

FOR FIXTURE WITH FACTORY-ATTACHED POWER SUPPLY CORD IN ACCESS PLATE ON BACK OF FIXTURE:

- Feed loose end of cord from inside of MB through hole in FH.
- Install MB with FH onto back of fixture by inserting (4) bolts/nuts protruding out back of fixture thru (4) keyholes in base of MB. Shift MB horizontally until all four bolts are positioned in narrow part of keyhole. NOTE: Access cover plate on MB is to run parallel with length of fixture, and align with two slots on fixture. Tighten all four machine nuts with wrench or nut driver.
- Lift fixture into position and attach FH onto existing mounting support (FBO).
- Make electrical connections from incoming power supply to fixture supply leads (cord). NOTE: Wire in accordance with all NEC requirements and any state, city or local codes. See page 3 for WIRING DIAGRAM.

HIGH BAY INDUSTRIAL

INSTALLATION INSTRUCTIONS

C. HOOK & CABLE MOUNTING

PARTS INCLUDED WITH HOOK AND CABLE KIT:

- (1) 3/4" Cast Fixture Hook with mounting plate.
- (4) Adjustable mounting cables with toggles.

TO INSTALL FIXTURE USING HOOK AND CABLES

FIG C.4.1

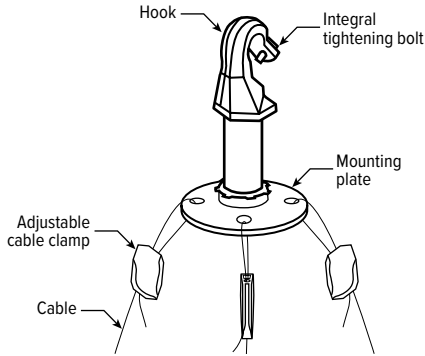

STEP 1: Attach hook to eye bolt or loop (FBO) with integral tightening bolt on hook.

STEP 2: Loop cables through holes in hook mounting plate, then push one end of the cable through the empty channel of the adjustable cable clamp. Pull the cable until you reach the desired length of cable to use from the hook to the fixture below.

STEP 3: Slip the toggles through holes/slots provided in fixture housing. See FIG C.3.2 for proper mounting appearance.

FIG C.3.1

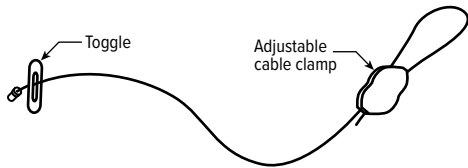
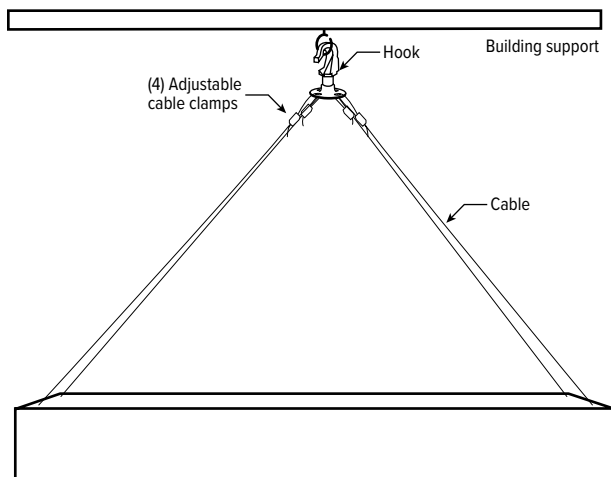

FIG C.3.2



BALANCING/STABILIZING FIXTURE

In some cases the fixture will not hang level due to ballast(s) mounting, EM packs, occupancy sensors, air movement, etc., which cause the fixture to be unbalanced. If this condition occurs, install the optional AC assembly to level and stabilize the fixture. Attach the two toggles on 'Y' cable through hanging holes on HEAVY end of fixture and attach other end of cable to a building support member using the adjustable gripper on cable. Adjust cable until fixture is level. See FIG C.3.3 for optional methods of attaching leveling cable.

FIG C.3.3

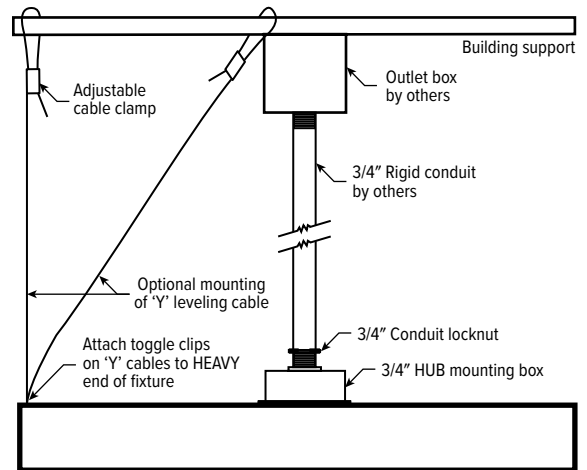

D. WIRING DIAGRAM

Make electrical connections in accordance with NEC and local codes.

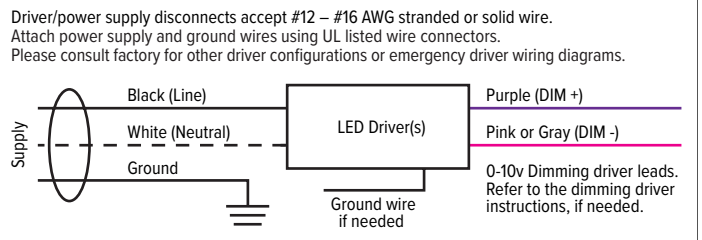

HIGH BAY INDUSTRIAL

INSTALLATION INSTRUCTIONS

E. GH SMK INSTALLATION

FOR USE WITH GH

NOTE: 4' fixture requires two brackets for mounting.

FIG E.0.1 2'

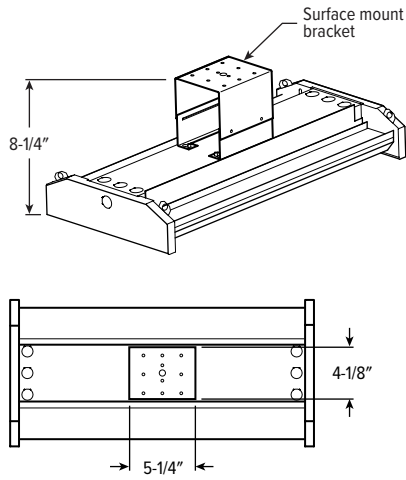

4'

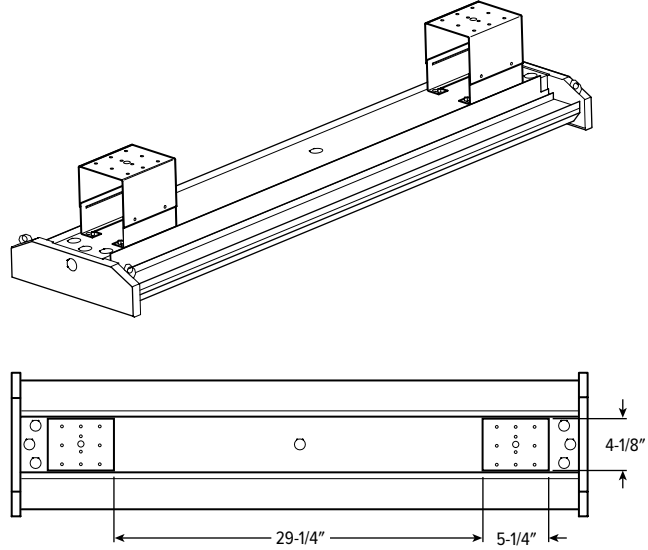
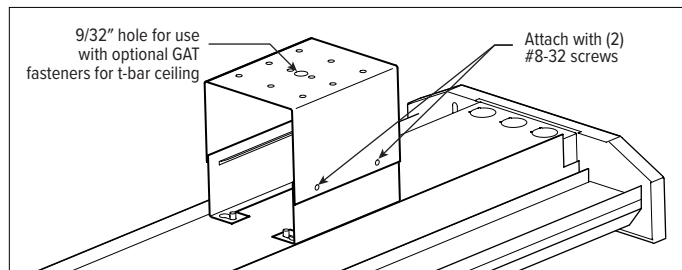

FIG E.0.2



HIGH BAY INDUSTRIAL

INSTALLATION INSTRUCTIONS

F. GS SMK INSTALLATION

FOR USE WITH GS

CROSS SECTION

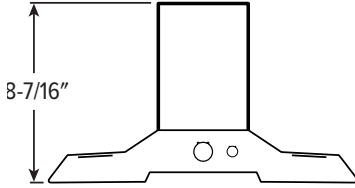

BACKVIEW

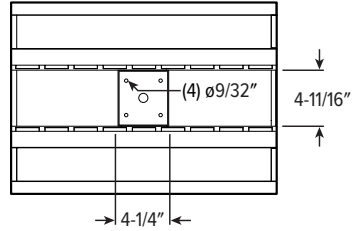

STEP 1: Align the (4) hook tabs into the corresponding slots in the back of the fixture housing.

STEP 2: Slide the surface mount bracket in the appropriate direction to engage the hooks. This movement should fully reveal the mounting screw holes.

STEP 3: Install (4) #8 screws from the sides of the housing and into the holes in the hook tabs to secure the SMK bracket to the fixture. See FIG F.3.1

FIG F.3.1

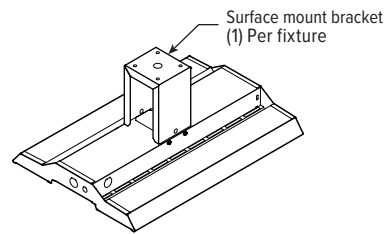
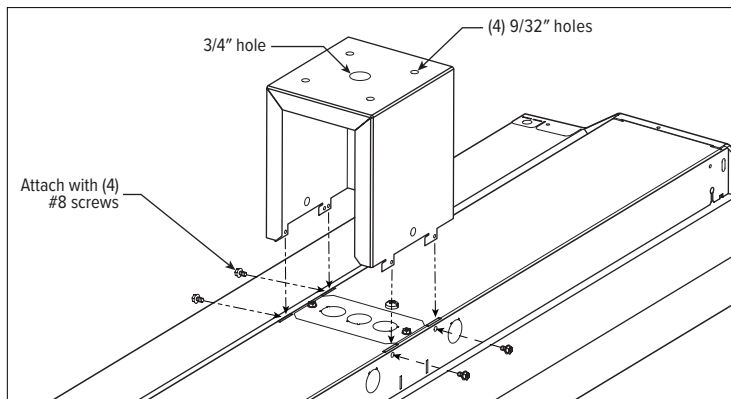

HIGH BAY INDUSTRIAL

INSTALLATION INSTRUCTIONS

G. GS HUB INSTALLATION

FOR USE WITH GS

GS-HUB MT

CROSS SECTION

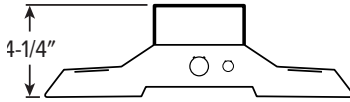

A 10' aircraft cable and Y style hanger factory furnished for leveling fixture from single support.

BACKVIEW

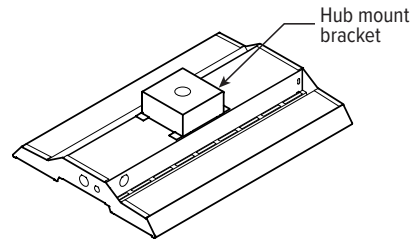
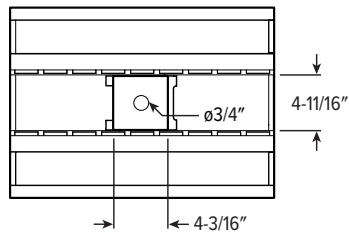

STEP 1: Install stem, by others.

- A. Thread locknut onto the end of the stem until it stops.

FIG G.1.1

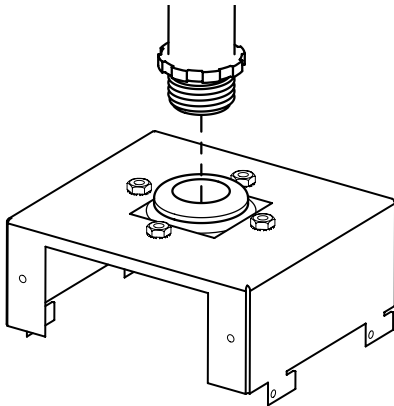

- B. Thread the stem into the hub mount until it makes contact.

FIG G.1.2

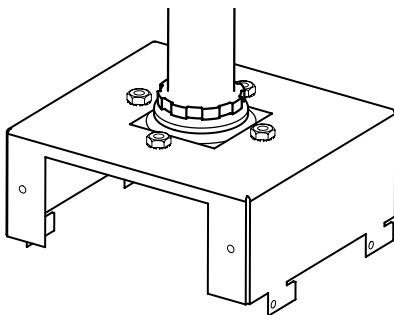

- C. Tighten to engage the lock nut teeth to prevent rotation.

STEP 2: Install hub

- A. Align the (4) hook tabs on the hub mount box into the corresponding slots in the back of the fixture housing.
- B. Slide the hub mount in the appropriate direction to engage the hooks. This movement should fully reveal the mounting screw holes.
- C. Install (4) #8 screws from the sides of the housing and into the holes in the hook tabs to secure the hub mount box to the fixture.

FIG G.2.1

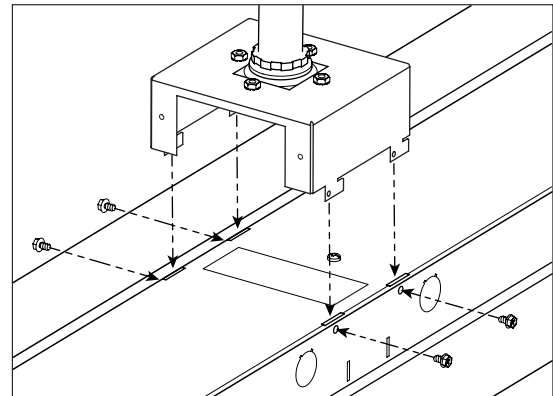

STEP 3: Install hub mount cover

- A. Make electrical connections in accordance with local codes. See page 3 for WIRING DIAGRAM
- B. Install the hub mount cover plate using (2) #8 screws.

FIG G.3.1

