

LRXF SERIES

INSTALLATION INSTRUCTIONS



WARNING:

- This product must be installed in accordance with the applicable installation code by a person familiar with the construction and operation of the product and the hazards involved.
- Make sure all electrical power is turned off while installing the fixture.
- This luminaire must be adequately grounded for protection against shock hazards and to assure proper operation.
- Disconnect power before servicing.
- LEDs are ESD (Electro Static Discharge) sensitive devices that can be easily damaged if the proper ESD mitigating steps are not taken.
- LEDs are very sensitive to mechanical damage. Caution must be taken to avoid damage to the LEDs.
- ESD or mechanical damage voids all warranties.
- Suitable for dry or damp locations.

FOR USE WITH:

- LRX2F
- LRX3F
- LRX4F
- LRX5F

TABLE OF CONTENTS

CROSS SECTIONS	1	B. CONTINUOUS ROW FIXTURE MOUNTING	3
A. STAND-ALONE FIXTURE INSTALLATION.....	1		

CROSS SECTIONS

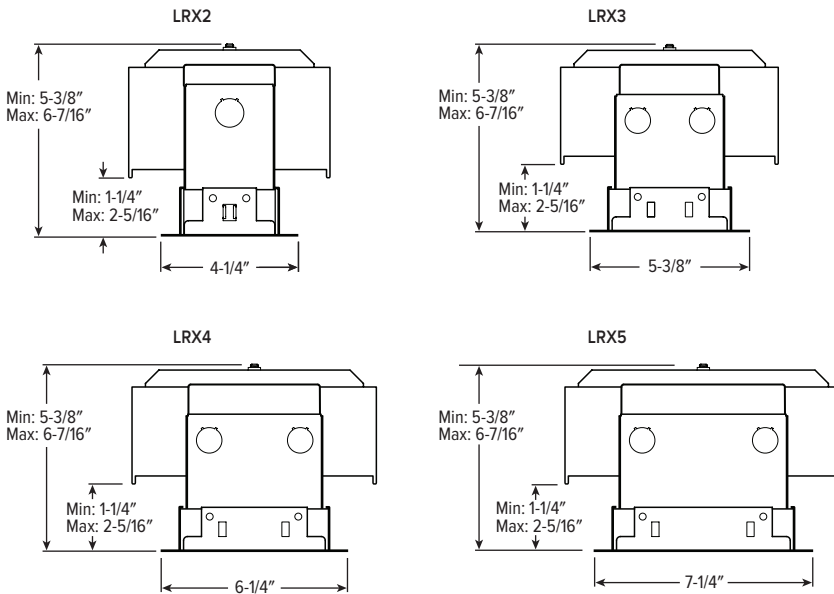

RECOMMENDED CEILING OPENING				
	LRX2	LRX3	LRX4	LRX5
2'	3-5/8" x 24"	4-5/8" x 24"	5-5/8" x 24"	6-5/8" x 24"
4'	3-5/8" x 48"	4-5/8" x 48"	5-5/8" x 48"	6-5/8" x 48"
6'	3-5/8" x 72"	4-5/8" x 72"	5-5/8" x 72"	6-5/8" x 72"
8'	3-5/8" x 96"	4-5/8" x 96"	5-5/8" x 96"	6-5/8" x 96"

For continuous row mounting, add 24" for each additional 2' of row length

LRXF SERIES

INSTALLATION INSTRUCTIONS

A. STAND-ALONE FIXTURE INSTALLATION

STEP 1: Remove lens and internal wireway cover to expose electrical components.

FIG A.1.1

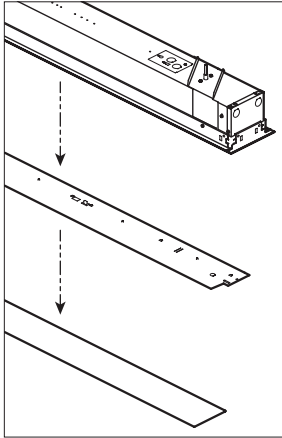

STEP 2: Remove access plate on the back of the stand-alone or feeder fixture. Remove driver supply wires and make electrical connections in accordance with local codes (ground screw provided on access plate). Re-install access plate.

FIG A.2.1

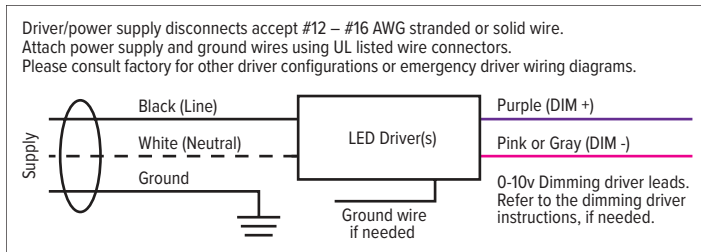

STEP 3: Verify that the swing-out brackets are collapsed, setting against the fixture housing. Lift fixture into prepared ceiling opening.

FIG A.3.1

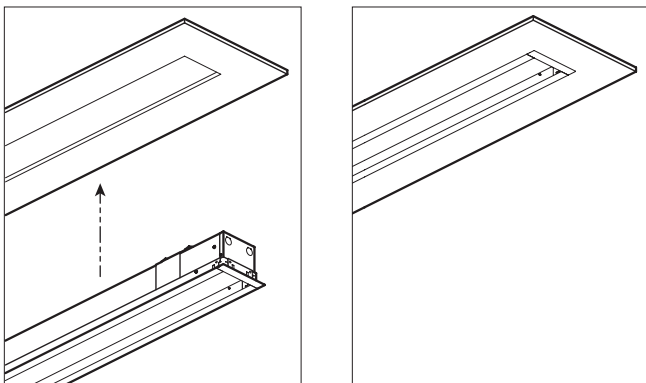

STEP 4: Locate swing-out arm handles inside fixture. Use handles to push swing-out bracket up and rotate so that swing-out bracket rests on ceiling support structure (when engaged correctly, fixture will hang slightly below ceiling plane).

FIG A.4.1

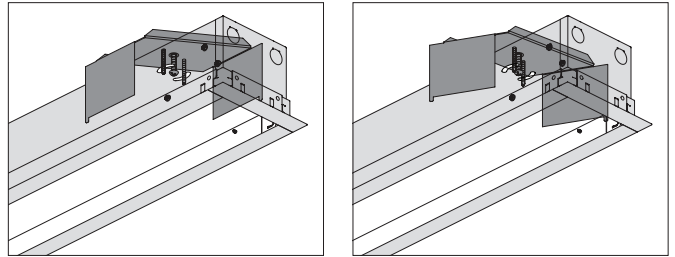

STEP 5: While keeping swing-out bracket rotation engaged, tighten screw located between handles inside fixture. As this screw is tightened, the swing-out bracket will clamp onto ceiling support structure and lift the fixture into place, flush with the ceiling plane.

FIG A.5.1

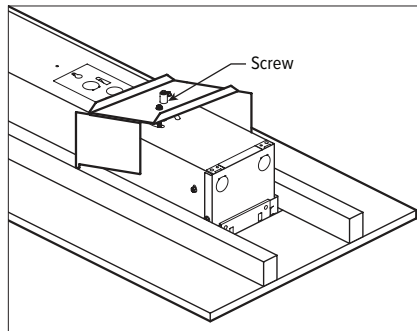

STEP 6: Re-install internal wireway cover and lens.

LRXF SERIES

INSTALLATION INSTRUCTIONS

B. CONTINUOUS ROW FIXTURE MOUNTING

STEP 1: Repeat steps 1-2 from stand-alone fixture installation instruction for first fixture in row mount application. See page 1.

STEP 2: Insert side connectors in drywall flange extrusions on fixture (1 per side). When installed correctly, connectors will snap into place.

FIG B.2.1

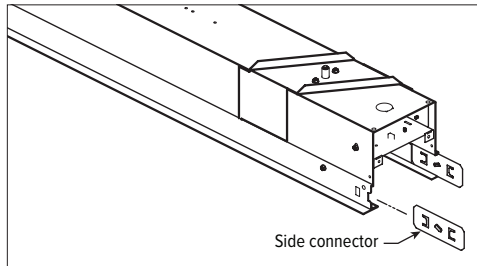

STEP 3: Install next fixture in row mount application (joiner fixture or ender fixture).

- A. Make electrical connections between fixtures with quick connect wiring harness.
- B. Butt fixtures together, allowing side connector extending from the first fixture to snap into the open extrusion of the next fixture. See FIG B.3.1
- C. Repeat this step for each additional fixture in row.

FIG B.3.1

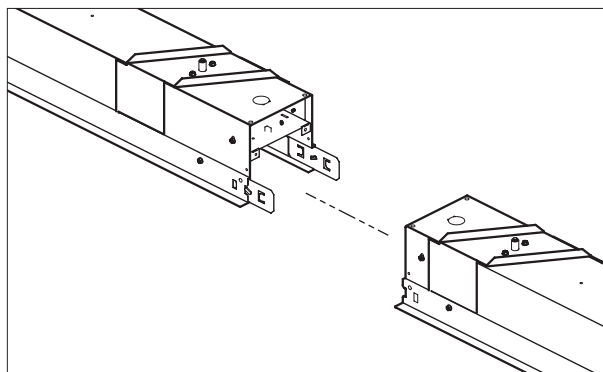

STEP 4: Repeat steps 3-5 from stand-alone fixture installation instructions to complete row installation.

STEP 5: Use provided screws to fasten fixtures together at intersections (2 screws per intersection). Re-install internal wireway covers.

FIG B.5.1 For use with LRX3, LRX4, LRX5

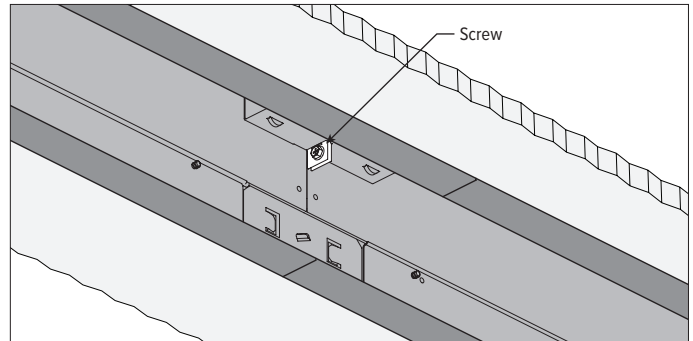
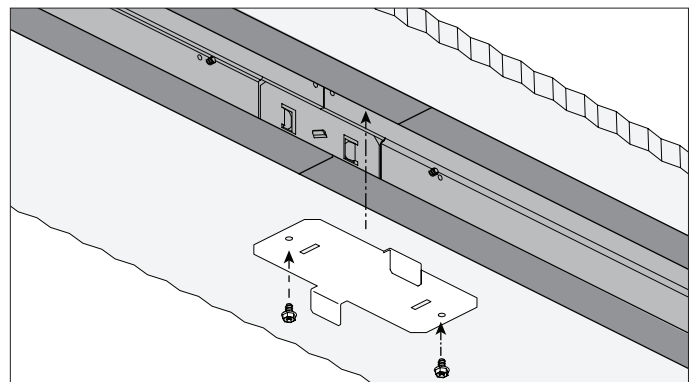
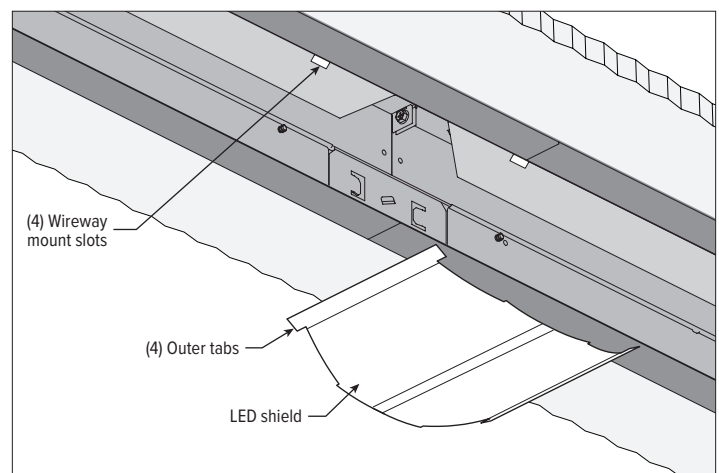

FIG B.5.2 For use with LRX2



STEP 6: To prevent light leak, install LED shield at fixture intersection(s) by snapping (4) outer tabs into (4) wireway cover mount slots at all fixture intersections.

FIG B.6.1



STEP 7: Re-install lenses.