

MCTM | MCTMB SERIES

INSTALLATION INSTRUCTIONS



WARNING:

- This product must be installed in accordance with the applicable installation code by a person familiar with the construction and operation of the product and the hazards involved.
- Make sure all electrical power is turned off while installing the fixture.
- This luminaire must be adequately grounded for protection against shock hazards and to assure proper operation.
- Disconnect power before servicing.
- LEDs are ESD (Electro Static Discharge) sensitive devices that can be easily damaged if the proper ESD mitigating steps are not taken.
- LEDs are very sensitive to mechanical damage. Caution must be taken to avoid damage to the LEDs.
- ESD or mechanical damage voids all warranties.
- Suitable for wet location under covered ceiling.

TABLE OF CONTENTS

TABLE OF CONTENTS.....	1	NEMA TYPE "F" INSTALLATION	2
FIXTURE ORIENTATION.....	1	LOW-VOLTAGE CONTROLLER WIRING	3
NEMA TYPE "G" INSTALLATION (FOR USE WITH MCTM ONLY).....	1	TYPICAL WIRING DIAGRAM.....	3

FIXTURE ORIENTATION

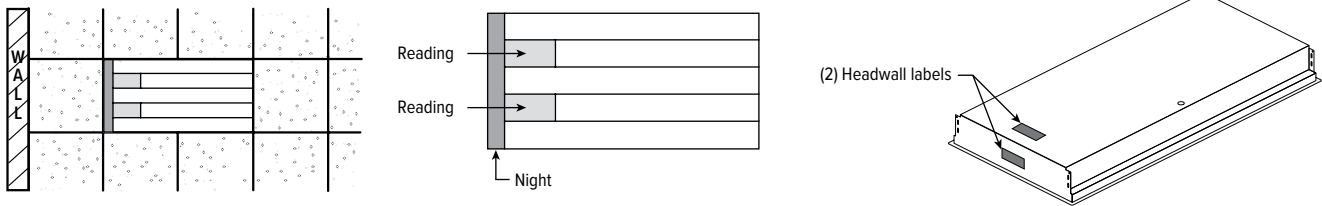

NEMA TYPE "G" INSTALLATION (FOR USE WITH MCTM ONLY)

WHAT IS A NEMA "G" (GRID) FIXTURE?

All Williams grid fixtures (NEMA Type "G") are designed to fit securely into a standard NEMA Type "G", 1" nominal T-bar system.

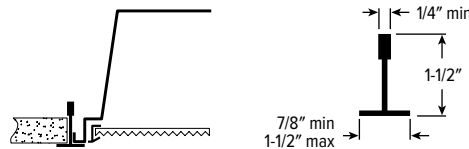

- STEP 1:** Follow the steps below to install the fixture(s) into a ceiling system:
- Raise the fixture through the ceiling opening and rest the fixture in the grid system.
 - Center the fixture within the opening.
 - Use earthquake clips or integral T-bar clips to secure the fixture to the ceiling structure for added stability.
 - Refer to local codes for other installation requirements.
 - Make electrical connections per NEC and all applicable local electrical codes. See FIG 2.3)

NOTE: Supply wires are brought out of access hole by factory. No need to open fixture.

BACKVIEWS

2x2

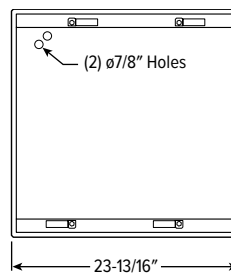

2x4

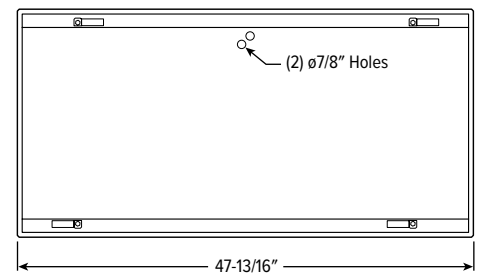

MCTM | MCTMB SERIES

INSTALLATION INSTRUCTIONS

NEMA TYPE "F" INSTALLATION

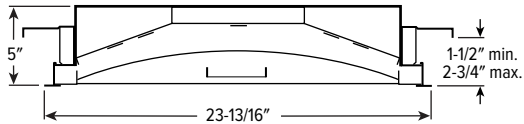

	ROUGH-IN	FINISH TRIM SIZE
2x2	22-15/16" x 22-13/16"	23-13/16" x 23-13/16"
2x4	22-15/16" x 46-13/16"	23-13/16" x 47-13/16"

For continuous row mounting, add 47-13/16" for each additional fixture to obtain ceiling opening. 3/4" between end plates.

STEP 1: Complete necessary electrical connections:

- A. Remove door frame and lens assembly to expose internal components.
- B. Make electrical connections per NEC and all applicable local electrical codes. See TYPICAL WIRING DIAGRAM on page 3. **NOTE:** Supply wires are brought out of access hole by factory. No need to remove wireway cover.

STEP 2: Install the fixture(s) into a ceiling system:

- A. See FIXTURE ORIENTATION section.
- B. Make sure the swing-out arms are collapsed, setting against the fixture housing. (See FIG 2.5). With assistance, lift the fixture into the prepared ceiling opening.
- C. Locate the swing-out arm screws in the fixture housing, near where the door frame would rest in the fixture. (See FIG 2.5). Tighten the swing-out screws to engage the swing-out arms so that they clamp onto the ceiling support structure. (See FIG 2.6).

NOTE: Additional ceiling support may be used around the ceiling opening to aid in fixture installation.

- D. Once the fixture is secured and locked in place, replace the door frame and lens assembly.

FIG 2.5

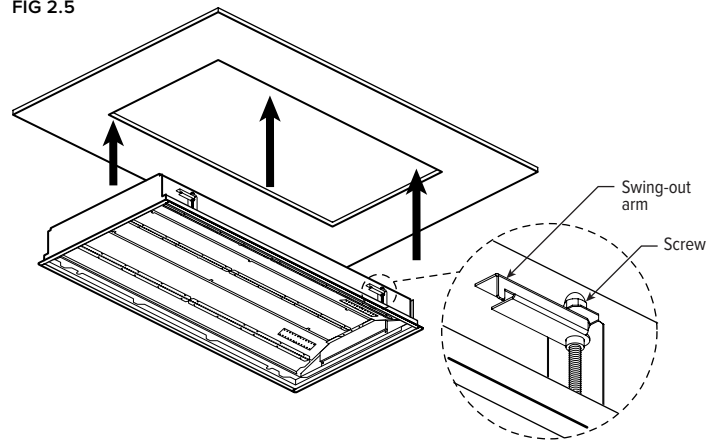
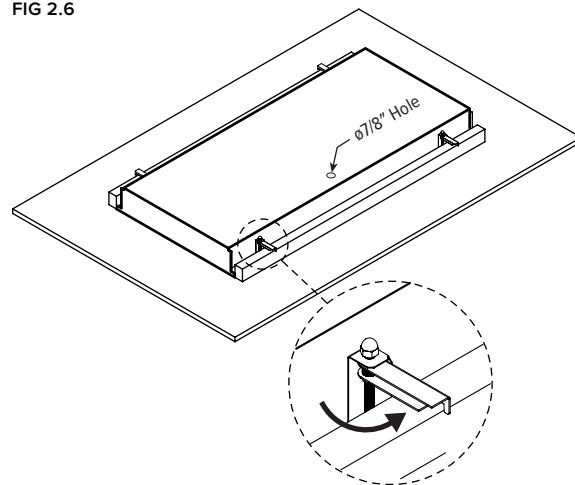

FIG 2.6



SEE NEXT PAGE FOR WIRING DIAGRAMS

MCTM | MCTMB SERIES

INSTALLATION INSTRUCTIONS

LOW-VOLTAGE CONTROLLER WIRING

LINE VOLTAGE WIRING DESIGNATIONS

- Low Voltage Relay Supply (unswitched line voltage supply)
- Exam
- Night Light
- Ambient
- Reading
- Emergency (unswitched line volt supply)
- Green - Ground
- White - Common for all line voltage supply leads.

Line voltage supply wires for each appropriate lighting aperture. (These are power supply wires which are not being controlled through a low voltage controller inside the fixture and that require switching external to the fixture.)

LOW VOLTAGE DESIGNATIONS

Connect 'Low Voltage Commons' with each of the 'Low Voltage' wires as labeled below using a dry contact, normally open switch.

- Low Voltage Common
- Low Voltage Ambient
- Low Voltage Reading
- Low Voltage Night
- Low Voltage Exam

Fixture may not be equipped with all of these low voltage functions.

LOW-VOLTAGE CONTROLLER

EXAMPLE: LVC3A/R/N			
CONTROLLER	LOAD 1	LOAD 2	LOAD 3
LVC1 1-circuit	A Ambient N Night R Reading E Exam		
LVC2 2-circuit	A/ Ambient R/ Reading	A Ambient N Night R Reading E Exam	
LVC3 3-circuit or dimming control	A/ Ambient R/ Reading DIMA/ Ambient, 0-10 dimming ¹ DIMR/ Reading, 0-10 dimming ¹	A/ Ambient N/ Night R/ Reading E/ Exam	N Night E Exam
	DIMA/DIMR/ Ambient and reading, 0-10 dimming ¹ SEGAR/ Ambient and reading, sequential switching ²		

¹ Smooth dimming of the load utilizing a single, dry contact, momentary, normally open switch which will dim from 25% up to 100% while holding down the switch.

² Alternating off and on of (2) loads with multiple cycles of one switch.

TYPICAL WIRING DIAGRAM

WIRING DIAGRAM DEPICTS:

1. Low voltage remote switch for control of ambient lighting
2. Low voltage remote switch for control of reading lamp
3. Low voltage entry (wall) switching of ambient lighting
4. Line voltage head wall switching of exam & night lighting

