

MX2W LED SERIES

INSTALLATION INSTRUCTIONS



WARNING:

- This product must be installed in accordance with the applicable installation code by a person familiar with the construction and operation of the product and the hazards involved.
- Make sure all electrical power is turned off while installing the fixture.
- This luminaire must be adequately grounded for protection against shock hazards and to assure proper operation.
- Disconnect power before servicing.
- LEDs are ESD (Electro Static Discharge) sensitive devices that can be easily damaged if the proper ESD mitigating steps are not taken.
- LEDs are very sensitive to mechanical damage. Caution must be taken to avoid damage to the LEDs.
- ESD or mechanical damage voids all warranties.
- Suitable for dry and damp locations.

TABLE OF CONTENTS

STAND-ALONE ASSEMBLY.....	1
ROW MOUNT ASSEMBLY.....	2

WIRING DIAGRAM.....	4
---------------------	---

STAND-ALONE ASSEMBLY

STEP 1: Attach J-box cover to mounting bracket with two 8-32 x 1/4" hex head Phillips screws (provided). Break off row mount tab when installing stand-alone assembly.

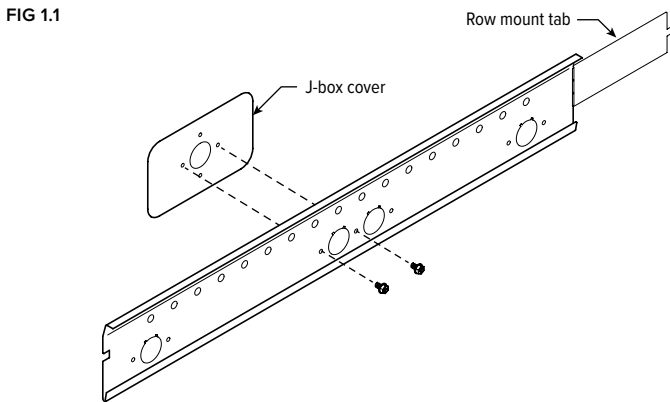

STEP 2: J-box installation

- With J-box cover attached, level and secure mounting bracket to wall. Position so that J-box cover completely encloses the J-box and any mounting holes will align with wall studs, if possible.
- Use hardware appropriate for surface to which you are mounting (hardware by others).

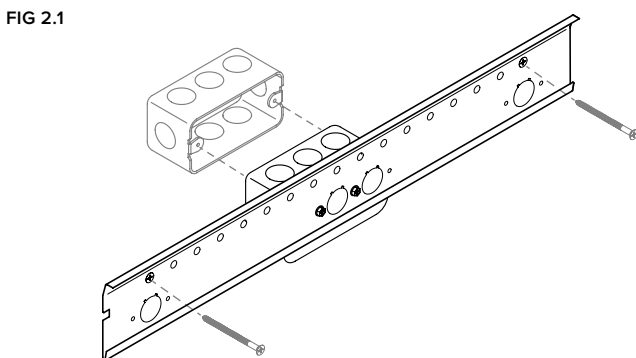

C. Feed wires through J-box cover and wall mount bracket.

STEP 3: Temporarily hang fixture from bottom of bracket to help facilitate wiring. Wires will feed through the notch at back of fixture to clear bracket. See FIG 3.1

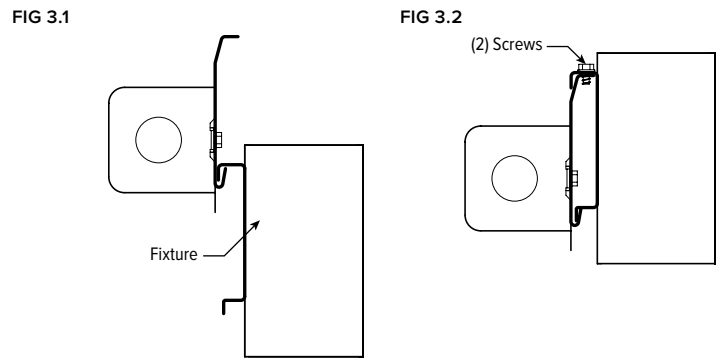

STEP 4: See "WIRING DIAGRAM" on page 4. After connecting wires, hang fixture on bracket. See FIG 3.2

- Both top and bottom of fixture lock securely, and all wires are enclosed between fixture and wall bracket.
- Bend tabs in on mounting bracket to close off access to wires.
- Install two 8-32 x 1/4" hex head Phillips screws (provided) to secure fixture to mounting bracket.

MX2W LED SERIES

INSTALLATION INSTRUCTIONS

STEP 5: LENS INSTALLATION FOR TOP LENS (UP/DOWN ONLY)

FLAT LENS WITH WIDESPREAD OPTIC (FW)

- A. Note correct orientation for installation.

FIG 5.1



- B. Maintain consistent orientation for all additional lenses in the row.

FLAT LENS WITH ASYMMETRIC OPTIC (FA)

- A. FA is an asymmetric optic that must be installed in a certain orientation, depending on the desired direction of throw.

FIG 5.2

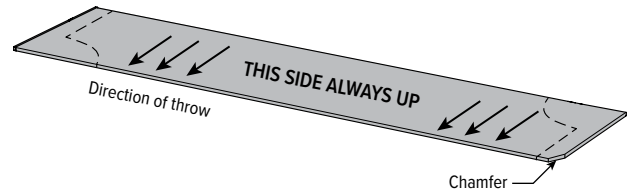

NOTE: Direction of throw is determined by the orientation of the small chamfer on (1) corner of the lens.

NOTE: Do NOT break off end section of lens.

- B. Maintain consistent orientation for all additional lenses in the row.

ROW MOUNT ASSEMBLY

- STEP 1:** Attach J-box cover to mounting bracket with two 8-32 x 1/4" hex head Phillips screws (provided). Do not break off row mount tab when installing row mount assembly.

FIG 1.1

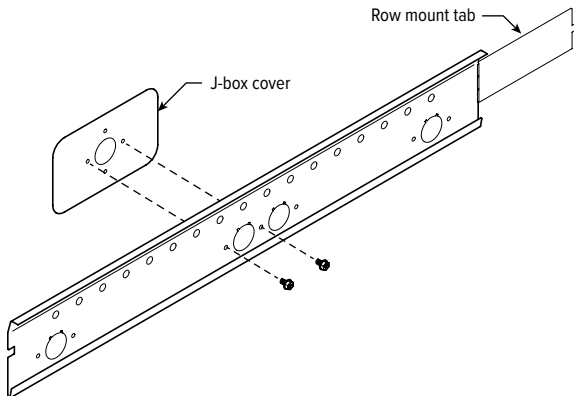

STEP 2: J-box installation

- A. With J-box cover attached, level and secure mounting bracket to wall. Position so that J-box cover completely encloses the J-box and any mounting holes will align with wall studs, if possible.
- B. Use hardware appropriate for surface to which you are mounting (hardware by others).

FIG 2.1

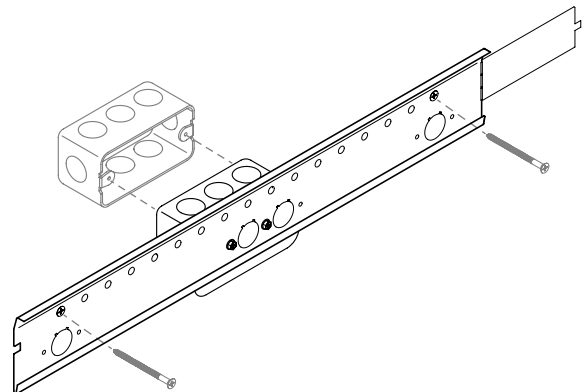

- C. Feed wires through J-box cover and wall mount bracket.

- STEP 3:** Use tab from first mounting plate to align subsequent mounting plate and secure to wall in same fashion. Repeat down the row. Break tab off of the last mounting plate in the row.

FIG 3.1

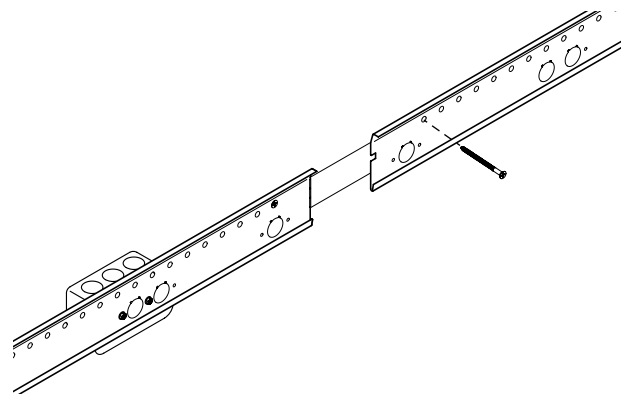

MX2W LED SERIES

INSTALLATION INSTRUCTIONS

STEP 4: Temporarily hang feeder fixture from bottom of bracket to help facilitate wiring. Wires will feed through the notch at back of fixture to clear bracket. See FIG 4.1

FIG 4.1

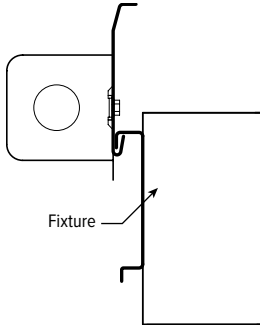
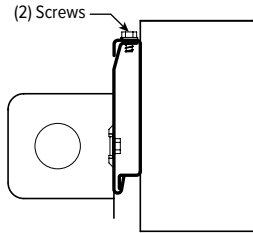

FIG 4.2



STEP 5: See “WIRING DIAGRAM” on page 4. After connecting wires, hang feeder fixture on bracket. See FIG 4.2

- A. Both top and bottom of fixture lock securely, and all wires are enclosed between fixture and wall bracket.
- B. Bend tabs in on mounting bracket to close off access to wires.
- C. Install two 8-32 x 1/4” hex head Phillips screws (provided) to secure fixture to mounting bracket.

STEP 6: Hang joiner/ender fixture from mounting bracket. Do not secure with screws at this time.

STEP 7: Align and join fixtures.

- A. Slide fixtures together, engaging row aligners in each fixture.

FIG 7.1

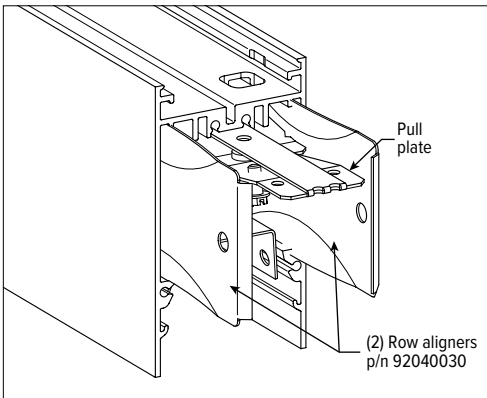

- B. Remove (2) screws from parking holes and place in pull plate alignment holes to secure the pull plate to the newly placed fixture.

FIG 7.2

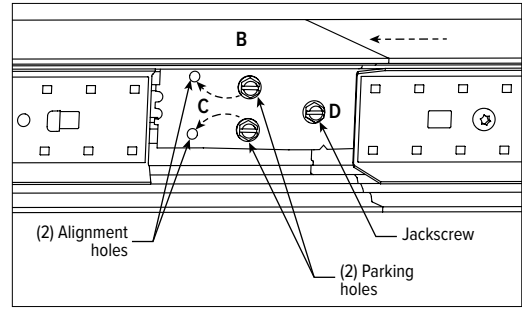

- C. Using center located jackscrew, draw the 2 fixtures tightly together. **Do not over tighten.**
- D. Make electrical connections between fixtures with quick connect wiring harness then slide inner LED cartridge back into place. See “WIRING DIAGRAM” on page 4.

STEP 8: Prevent light leak.

- A. Slide light block piece over each joint between fixtures. Visually center each piece.

FIG 8.1

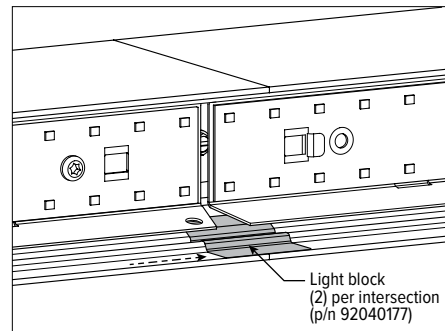

- B. To prevent light leak, bend LED shield and install by snapping (4) outer tabs into (4) wireway mount slots at all fixture intersections.

FIG 8.2

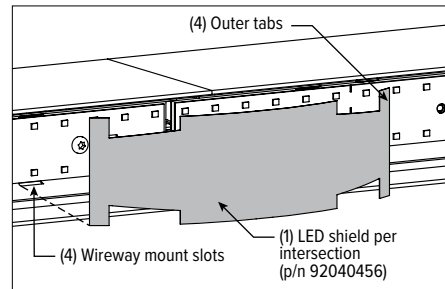

STEP 9: Repeat STEPS 6 – 8 for each additional fixture in row.

NOTE: Final (End) fixture in row will not have cartridge installed, to allow pull plate installation. Plug cartridge in and snap in place.

STEP 10: Reinstall lower lenses removed in STEP 7A.

MX2W LED SERIES

INSTALLATION INSTRUCTIONS

WIRING DIAGRAM

Make electrical connections in accordance with NEC and local codes.

