

PXF – GRAZE DISTRIBUTION

INSTALLATION INSTRUCTIONS



WARNING:

- This product must be installed in accordance with the applicable installation code by a person familiar with the construction and operation of the product and the hazards involved.
- Make sure all electrical power is turned off while installing the fixture.
- This luminaire must be adequately grounded for protection against shock hazards and to assure proper operation.
- Disconnect power before servicing.
- LEDs are ESD (Electro Static Discharge) sensitive devices that can be easily damaged if the proper ESD mitigating steps are not taken.
- LEDs are very sensitive to mechanical damage. Caution must be taken to avoid damage to the LEDs.
- ESD or mechanical damage voids all warranties.
- Suitable for dry and damp locations.

PARTS LIST

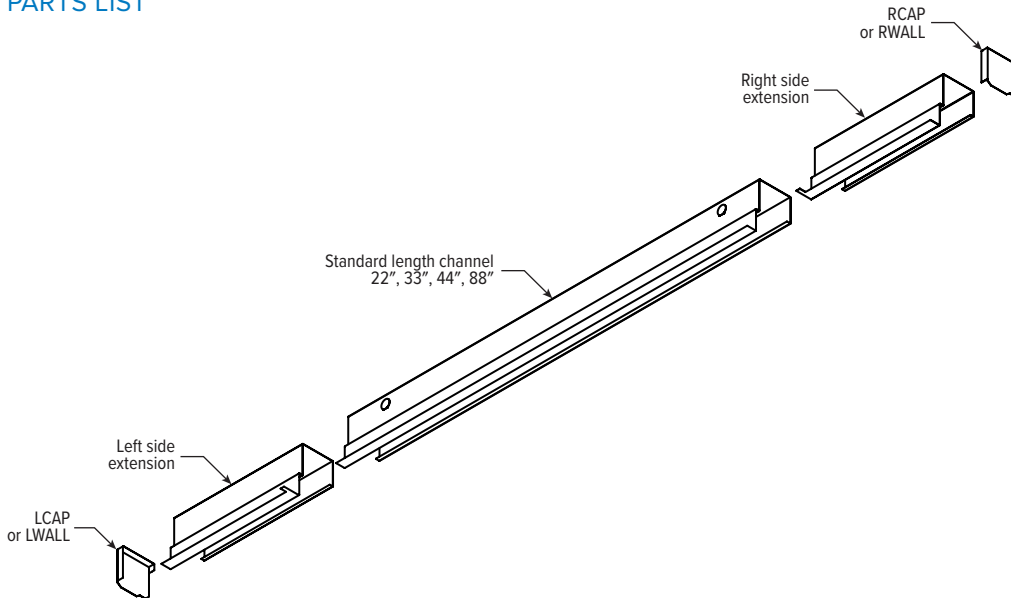

SHIPPED SEPARATELY

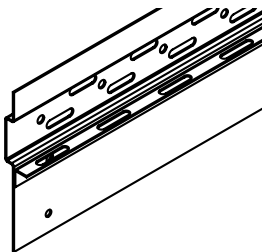

WALL BRACKET
88", CUT TO LENGTH
IN FIELD (P/N: 92042139)

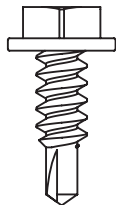

**#8 x 1/2 SELF
DRILLING SCREW**
(P/N: 92019812)

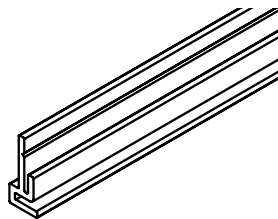

CLIP
88", CUT TO LENGTH
IN FIELD (P/N: 92039408)

PXF – GRAZE DISTRIBUTION

INSTALLATION INSTRUCTIONS

PXF – RIGID CEILING CROSS SECTION

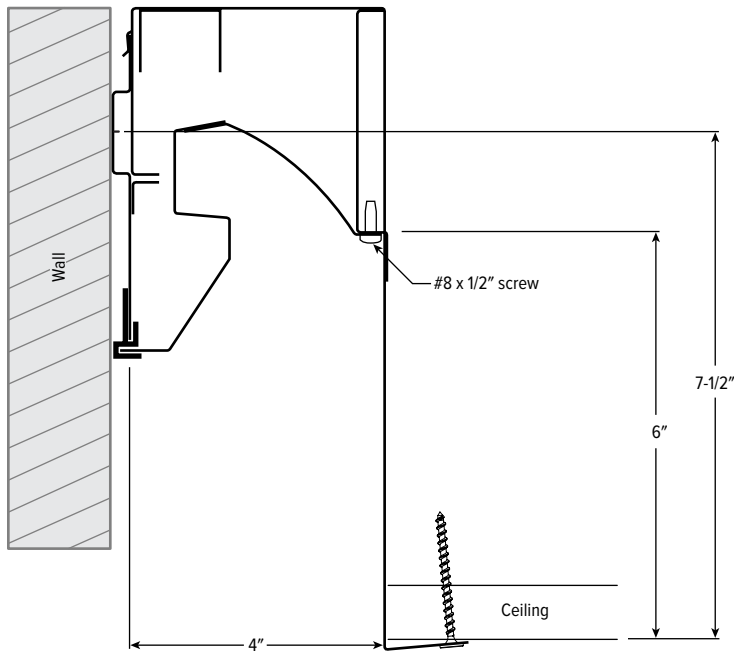

INSTALL WALL BRACKET

STEP 1: MARK WALL BRACKET LOCATION

FORMULA (see FIGURE 1.1):

Height of ceiling + 7-1/2" = bracket center position

EXAMPLE: 108" + 7-1/2" = 115-1/2" (mark bracket center position)

STEP 2: IMPORTANT: LEVEL BRACKET

STEP 3: WORKING FROM LEFT TO RIGHT, SECURE BRACKET TO WALL (SEE FIGURE 1.1)

- Use suitable fasteners for wall type.
- Secure to structural component of wall.
- Space fasteners at 20" or less.
- Drill additional holes in bracket if holes do not line up with wall structure.

STEP 4: ATTACH ADDITIONAL BRACKETS AS NECESSARY

- Keep brackets aligned and level - **CRITICAL**
- Butt brackets tightly end-to-end for entire span of fixture.
- Cut final bracket to length with scrap on the **RIGHT** side of the cut. If final piece will become too short to work with, reduce length of previous bracket.

NOTE: Extend wall bracket entire intended length of fixture install. **GAPS BETWEEN WALL BRACKETS WILL BE VISIBLE AFTER COMPLETED INSTALL.**

FIGURE 1.1

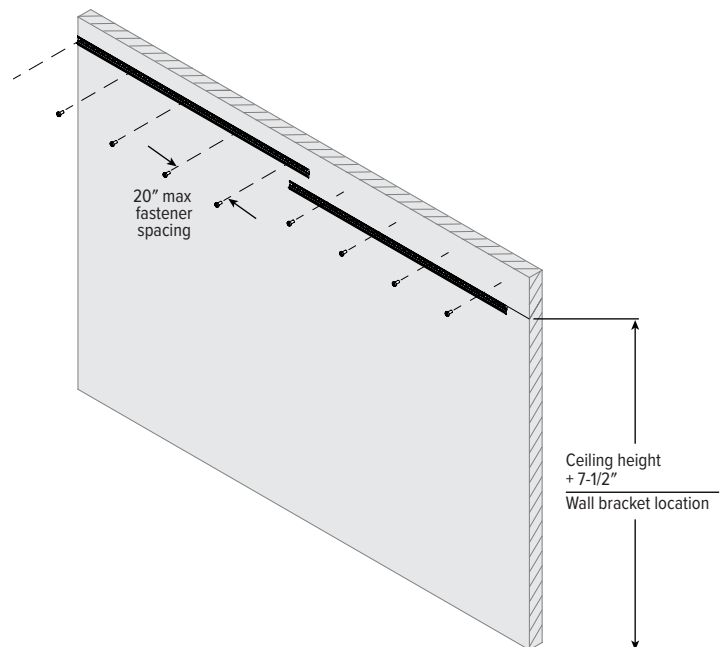

PXF – GRAZE DISTRIBUTION

INSTALLATION INSTRUCTIONS

STEP 5: INSTALL CLIP

- Add clips to bottom of wall bracket by attaching with supplied screws. See FIGURE 5.1
- Repeat entire length of wall bracket, cut final piece to fit.
- Gaps will be visible after completed install.

FIGURE 5.1

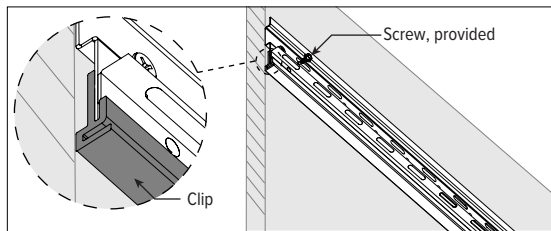

ATTACH PX TO WALL BRACKET

STEP 6: DISASSEMBLE LED MODULE AND REFLECTORS (FIGURE 6.1)

- Back out 3 screws per LED module. Screws do not need to be completely removed.
- LED modules will need to go back to their corresponding channels.

FIGURE 6.1

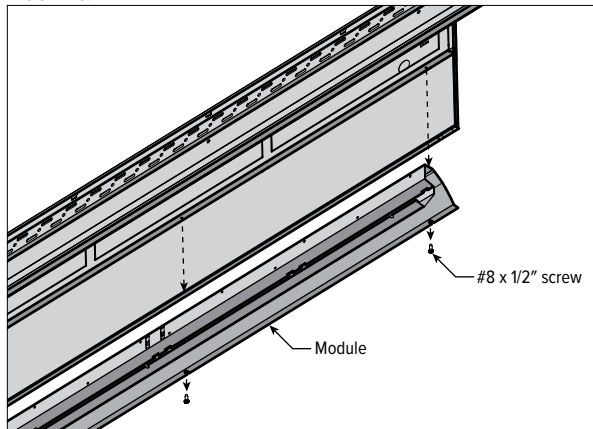

STEP 8: ADD ADDITIONAL FIXTURE HOUSINGS See FIGURE 8.1

- Fixture housings to be butted tightly end-to-end.
- Repeat steps 6 - 8 above.

FIGURE 8.1

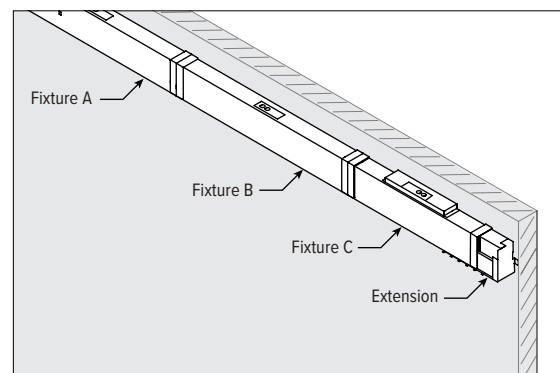

STEP 7: HANG FIRST FIXTURE HOUSING ON WALL BRACKET

- Consult supplied layout drawings to identify fixture locations.
- Work from left to right.
- Clips are designed and intended to fit tightly to the bracket. A quick pry with a screwdriver can adjust a clip that may be too tight.
- Confirm all fixture clips have engaged to the wall bracket.

NOTE: If run length contains 2 extensions, center standard fixture lengths so left and right side extensions will be extended near equal length. Locate first channel to the nearest securing screw locations (see FIGURE 10.1 and screw location detail in cross section on page 2).

PXF – GRAZE DISTRIBUTION

INSTALLATION INSTRUCTIONS

STEP 9: ADJUST FIXTURE EXTENSION TO LENGTH See FIGURE 9.1

- Fixture housing extension length can be adjusted to a maximum distance of 11-1/4".
- Secure fixture extension length by drilling 1/8" hole and inserting supplied #8 x 1/2" screw.
- Extensions may be provided on both left and right side for the fixture layout.

FIGURE 9.1

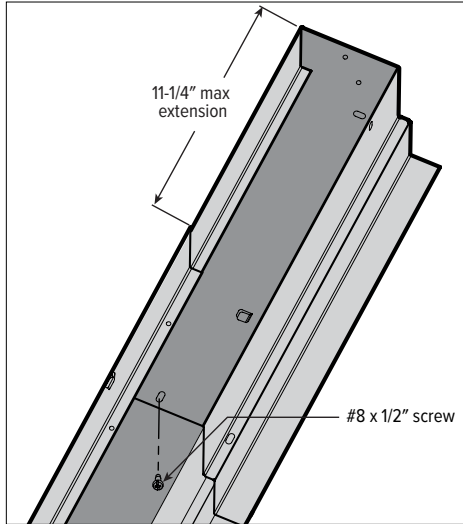

STEP 10: SECURE FIXTURES TO WALL BRACKETS See FIGURE 10.1

- Insert supplied #8 x 1/2" screw into wall bracket.
- Install screw approximately every 20".
- Drill 1/8" holes if fixture and wall bracket do not align.
- Reference channel cross section (page 2) for more detail.

FIGURE 10.1

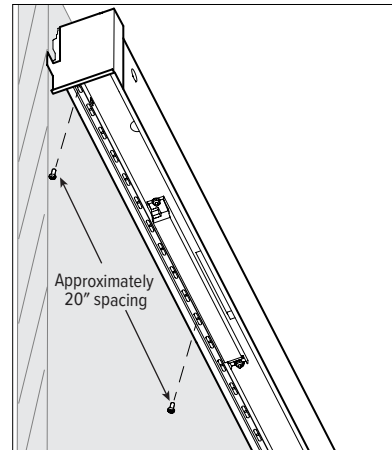

SECURE FLANGE

STEP 11: SECURE FLANGE TO RIGID CEILING

- Use appropriate fasteners to affix flange to adjacent rigid ceiling structure. See FIGURE 11.1
- Add drywall mud to hide flange and screws.
- Sand smooth and texture/paint with ceiling.
- Reference PXF cross section (page 2) for more detail.

FIGURE 11.1

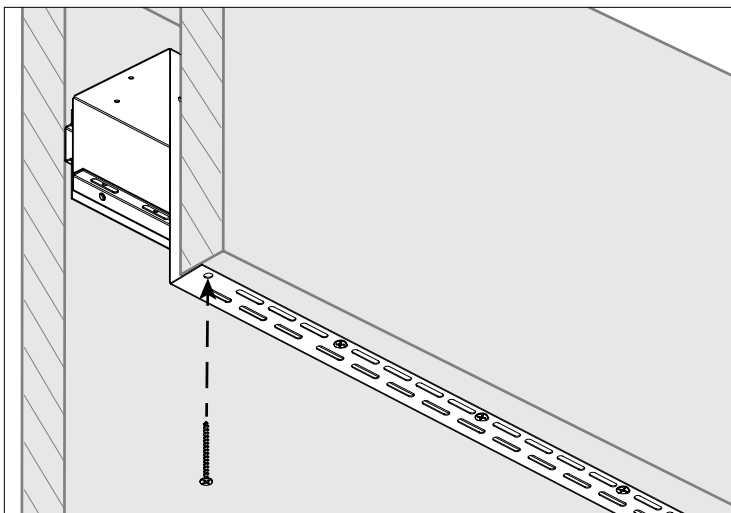

PXF – GRAZE DISTRIBUTION

INSTALLATION INSTRUCTIONS

CONNECT WIRING

STEP 12: CONNECT AC WIRING

- LED module removal provides full access to AC wiring channel.
- AC wiring enters fixture through provided 1/2" KOs.

FIGURE 12.1

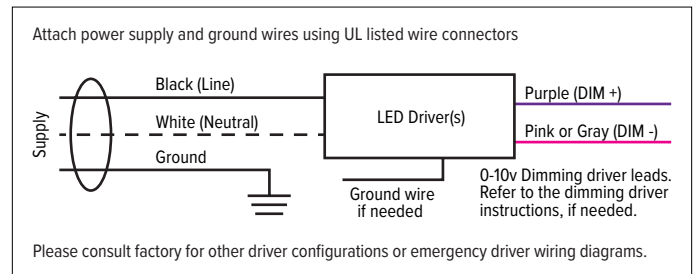

LED MODULE INSTALLATION

STEP 13: INSTALL & SECURE STANDARD LENGTH LED MODULE

NOTE: Assemble modules using the original channel assembly they were shipped with.

- Reattach module wiring using supplied quick connects.
- Reinstall supplied #8 x 1/2" white screws. (FIGURE 13.1)

NOTE: If an extension interferes with the location of a screw hole, discard that screw. The extension screw will retain both the extension and standard length LED module. (FIGURES 13.1 & 14.1)

FIGURE 13.1

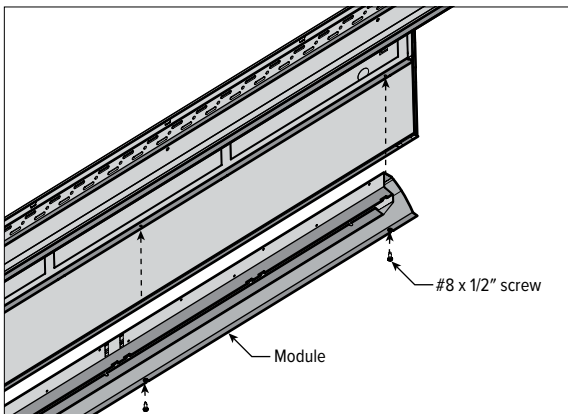

STEP 14: INSTALL & SECURE EXTENSION LED MODULES (FIGURE 14.1)

NOTE: Reassemble modules using the original channel assembly they were shipped with.

NOTE: Extension module will fit ovetop of standard length modules, overlapping LED rows. No dark spots will occur in run length.

- Reattach module wiring using supplied quick connects.
- Using 1/8" diameter drill bit, drill screw hole to affix extension module.
- Install supplied #8 x 1/2" long white screws.

FIGURE 14.1

