

SLOPED CEILING ADAPTOR

INSTALLATION INSTRUCTIONS LED DOWNLIGHTS



WARNING:

- This product must be installed in accordance with the applicable installation code by a person familiar with the construction and operation of the product and the hazards involved.
- Make sure all electrical power is turned off while installing the fixture.
- This luminaire must be adequately grounded for protection against shock hazards and to assure proper operation.
- Disconnect power before servicing.
- LEDs are ESD (Electro Static Discharge) sensitive devices that can be easily damaged if the proper ESD mitigating steps are not taken.
- LEDs are very sensitive to mechanical damage. Caution must be taken to avoid damage to the LEDs.
- ESD or mechanical damage voids all warranties.
- Suitable for dry and damp locations.

NEW CONSTRUCTION MOUNTING PAN INSTALLATION

STEP 1: Pre-attach the specified mounting hardware to the fixture pan. See FIGURES 1.1 - 1.3.

NOTE: Ceiling thickness range for standard SCA pan is 1/2" to 1-1/4". Consult factory for additional thicknesses.

FIG 1.1 2-Position fixed pan bracket.

F1: Universal bar hanger, shown | F2: T-bar clip hanger

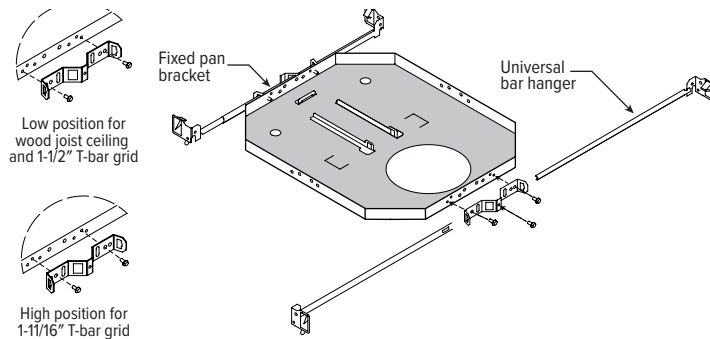

FIG 1.2 Adjustable butterfly pan bracket.

BA1: Butterfly bracket only | BA2: Heavy-duty universal bar hanger, shown.

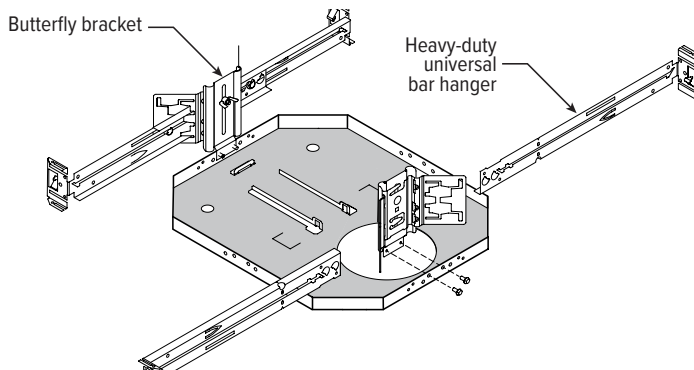
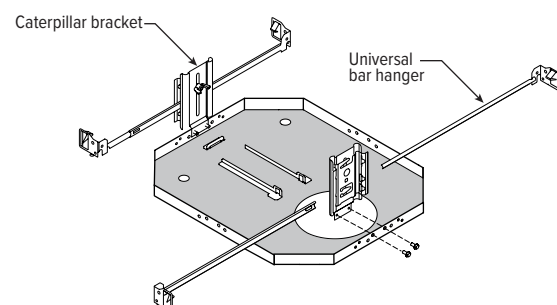

FIG 1.3 Adjustable caterpillar pan bracket.

CA1: Universal bar hanger, shown | CA2: T-bar clip hanger.



STEP 2: Install the SCA mounting pan with the junction box receiver bracket located uphill from the ceiling cutout.

STEP 3: Use the height adjustment screws to adjust the depth of the locating fingers so they are both flush with the ceiling plane. See FIG 3.1

FIG 3.1

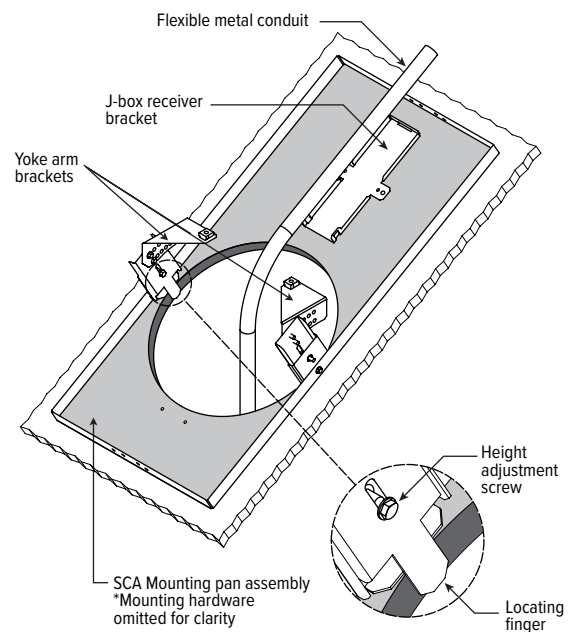

STEP 4: Orient yoke arm brackets parallel to the horizontal plane. Securely tighten the height adjustment screws. See FIG 4.1

NOTE: Verify preassembled yoke arm brackets are parallel to the horizontal plane.

FIG 4.1

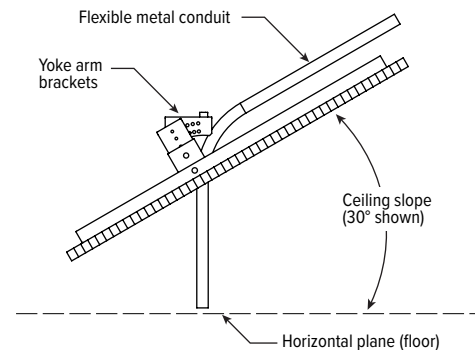

STEP 5: Route the flexible metal conduit down through the ceiling cutout to make it accessible for the next installation step. Continue to STEP 6.

SLOPED CEILING ADAPTOR

INSTALLATION INSTRUCTIONS LED DOWNLIGHTS

REMODEL MOUNTING PAN INSTALLATION

STEP 1: Insert remodel C-pan into position.

- A.** Maneuver the remodel C-pan up through the ceiling cutout. See FIG 1.B.1
- B.** Position the C-pan so that the expandable nailer bars are oriented uphill from the ceiling cutout and the pan's half-aperture is concentric with the ceiling cutout. See FIG 1.B.1

FIG 1.B.1

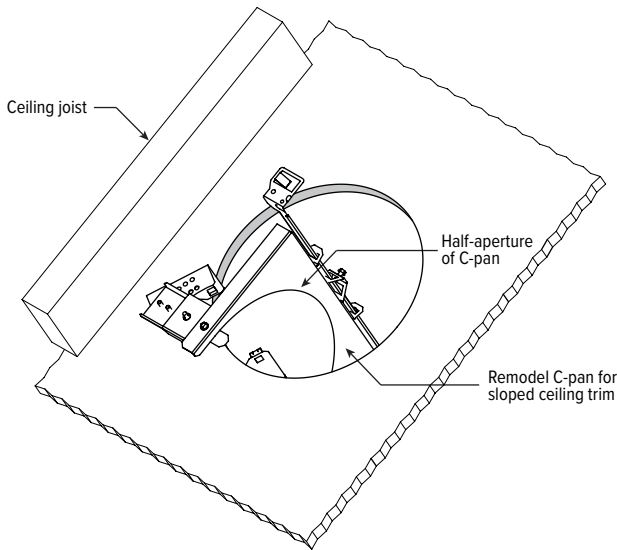

STEP 2: Temporarily secure remodel C-pan.

- A.** Adjust the depth of the locating fingers so that they are both flush with the ceiling plane. See FIG 2.1
- B.** Be sure to securely tighten the height adjustment screws.
- C.** Reach up through the ceiling cutout with a small hammer to tap the nailer bars into the adjacent ceiling joists.

FIG 2.1

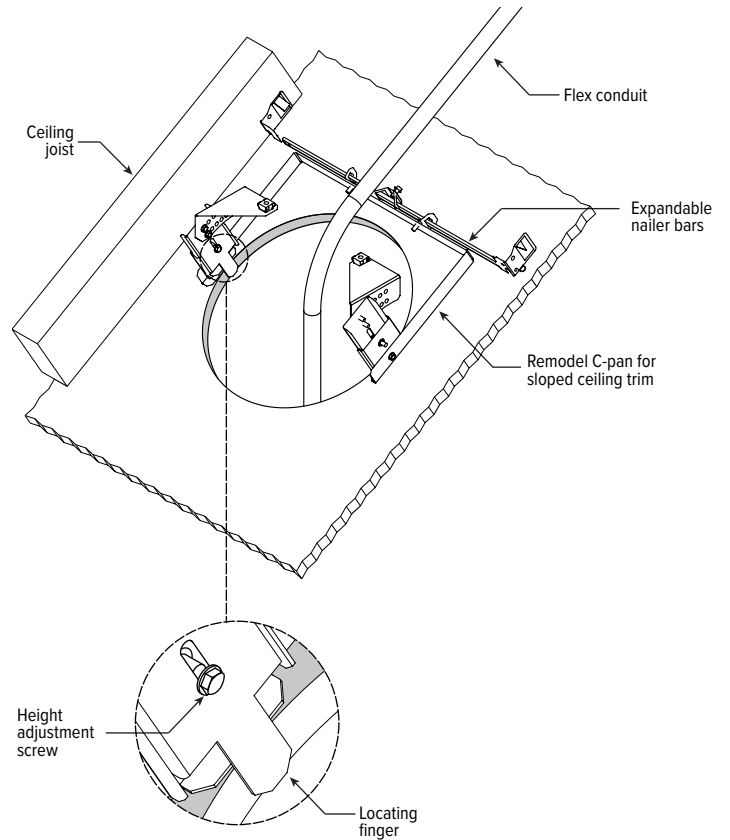

STEP 3: Route the flexible metal conduit down through the ceiling cutout to make it accessible for the next installation step. Continue to STEP 6.

SLOPED CEILING ADAPTOR

INSTALLATION INSTRUCTIONS LED DOWNLIGHTS

ELECTRICAL CONNECTIONS

STEP 6: Connect junction box to conduit.

- A. Pull the flexible conduit down through the ceiling cutout and connect the junction box. See FIG 6.1

FIG 6.1

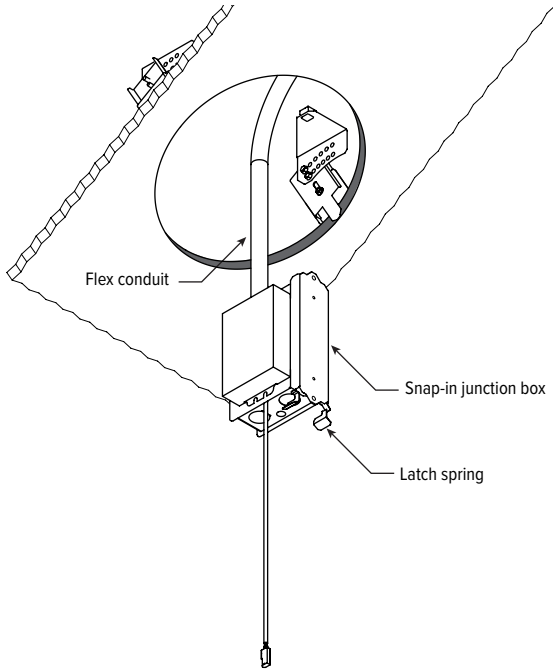

- B. Make all necessary lead terminations within the junction box. Attach power supply and ground wires using UL listed wire connectors. Ballast disconnect accepts #12 - #16 AWG stranded or solid wire. Re-attach the access cover.

FIG 6.2 Make electrical connections in accordance with NEC and local codes.

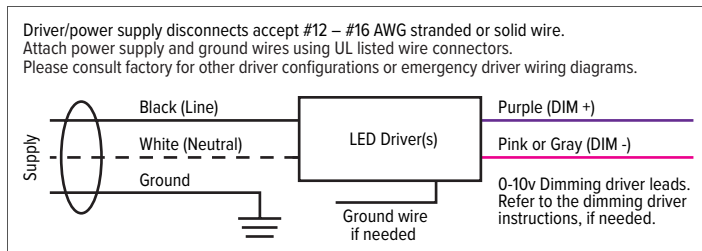

JUNCTION BOX INSTALLATION

STEP 7: NEW CONSTRUCTION: Install junction box to mounting pan (See FIG 7.1). Maneuver the junction box up through the ceiling cutout, rotate down 90 degrees, then slide back into the receiver bracket until the latch spring engages to lock it into the pan.

REMODEL: Place the junction box unattached just past the nailer bars.

FIG 7.1

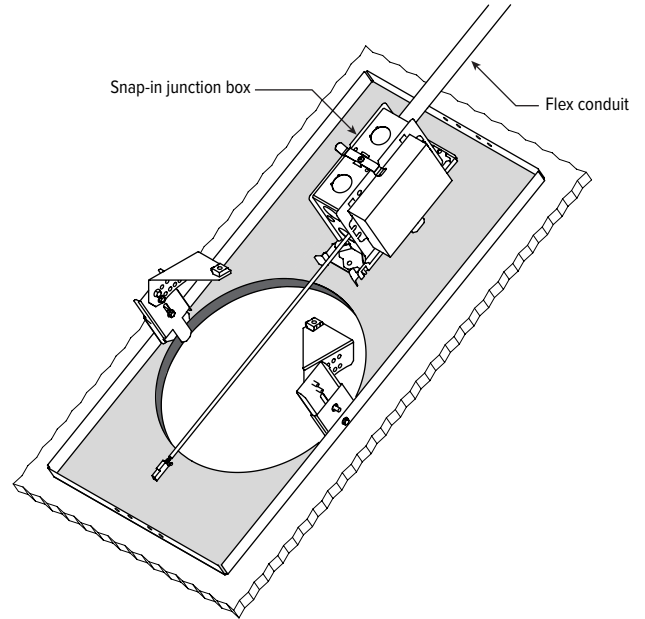

SLOPED CEILING ADAPTOR

INSTALLATION INSTRUCTIONS LED DOWNLIGHTS

TRIM INSTALLATION

STEP 8: Orient and align sloped ceiling trim. Align the trim mounting screws (2x) with the pre-installed cage nuts located in the yoke arm brackets. The lower stop ring must run parallel with the yoke arm brackets. See FIG 8.1

NOTE: Remove finishing ring that is taped to the inside of the sloped ceiling trim prior to its installation.

FIG 8.1

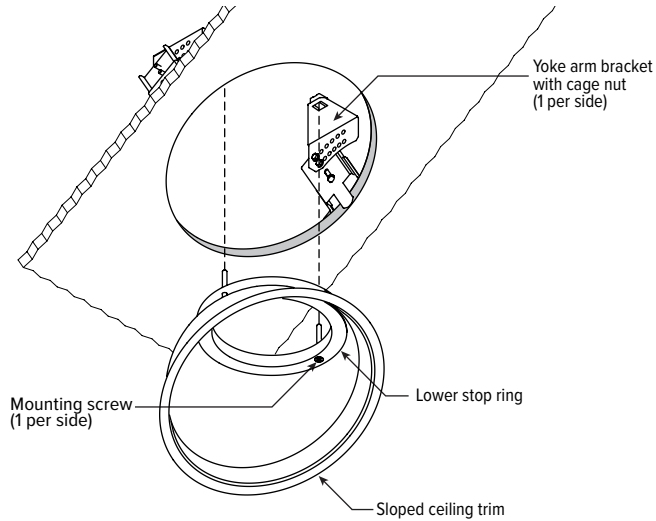

STEP 9: Install sloped ceiling trim.

- A. Lift the sloped ceiling trim up into the ceiling cutout so the mounting screws can engage the cage nuts.
- B. Tighten the screws until the trim flange has been drawn securely against the ceiling surface.
- C. Pull the LED power cable from the junction box down through the sloped ceiling so they are accessible for the downlight insert installation. See FIG 9.1

FIG 9.1

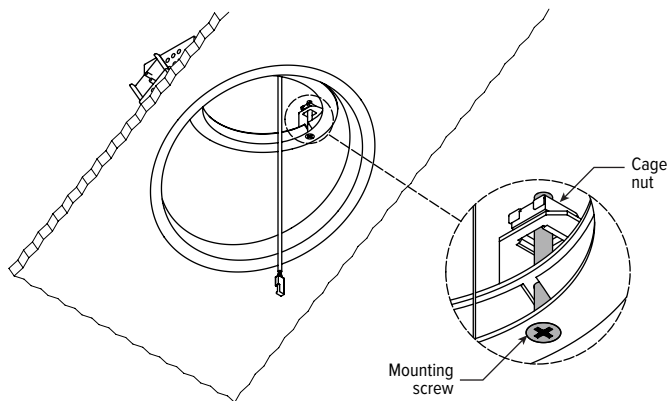

DOWNLIGHT INSERT INSTALLATION

STEP 10: Connect downlight insert to power. See FIG 10.1

- A. Terminate the LED power cable to the LED input cable on the downlight insert.

NOTE: Finishing ring slips down over downlight insert until it comes to rest on the stop tabs, prior to installation.

FIG 10.1

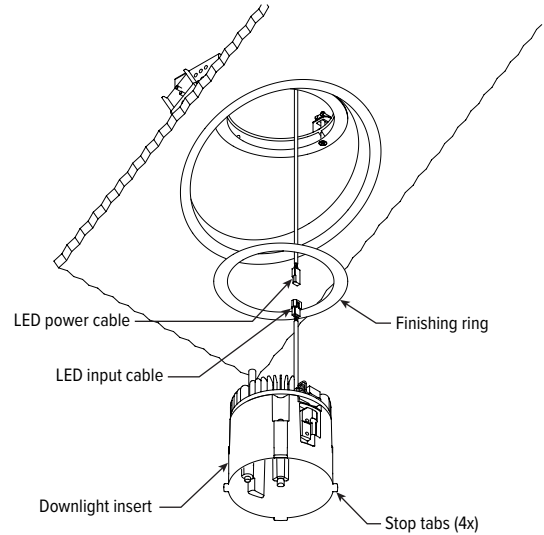

STEP 11: Install downlight insert to sloped ceiling trim. See FIG 11.1

- A. Maneuver the downlight insert up through the sloped ceiling trim until the stop tabs are flush against the lower stop ring.
- B. While continuing to support the insert, use a 9/64" hex bit to drive the installation screws - this will cause the swing-out arms to deploy, draw down, and clamp the insert against the upper stop ring.

FIG 11.1

