

# TLED LAMPING

## SURFACE & INDUSTRIAL INSTALLATION INSTRUCTIONS



### WARNING:

- This product must be installed in accordance with the applicable installation code by a person familiar with the construction and operation of the product and the hazards involved.
- Make sure all electrical power is turned off while installing the fixture.
- This luminaire must be adequately grounded for protection against shock hazards and to assure proper operation.
- Disconnect power before servicing.
- Caution - This luminaire cannot operate a fluorescent lamp.
- Risk of Fire or Electric Shock. Do not alter, relocate, or remove wiring, lamp holders, power supply, or any other electrical component.
- Luminaires are suitable for dry and damp locations only.
- LED tubes are not for use with dimmers.
- Do not install insulation within 76mm (3 in.) of any part of the luminaire, unless using Type IC Lamps.
- Complete all electrical connections with appropriate connectors/wires nuts as needed, per all local and national electrical codes.

### FOR USE WITH:

- 17 TLED
- 76 TLED
- GL TLED

### TABLE OF CONTENTS

FOR USE WITH:.....	1	TYPE C WITH EXTERNAL DRIVER WIRING DIAGRAMS.....	2
TYPE B WIRING DIAGRAMS .....	1		

#### STEP 1: Mount the fixture:

- Disconnect all power to the luminaire being worked on and remove the old luminaire from the ceiling.
- Decide on a hanging or mounting method that will work for your application. Make sure the new fixture is securely mounted to the ceiling structure.
- Refer to local codes for other installation requirements.

#### STEP 2: Complete necessary electrical connections:

- Connect AC Line wire to the new fixture wiring: Black to Black, White to White, and Green to Ground. Make sure all new connectors and wires are UL rated (90°C).
- Install lamps.
  - TYPE B: Ensure correct lamp orientation per (N) and (L) markings on fixture.
  - TYPE C: Lamps are not polarity sensitive and can be wired at either end.
- Make sure lamps are correctly seated in the lampholder (sockets) before twisting.

### TYPE B WIRING DIAGRAMS

FIG 1.1 Single End Direct Wiring Circuit Diagram For Non-Shunted Lampholders

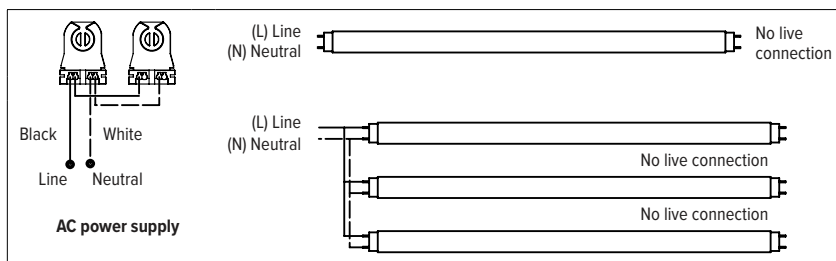
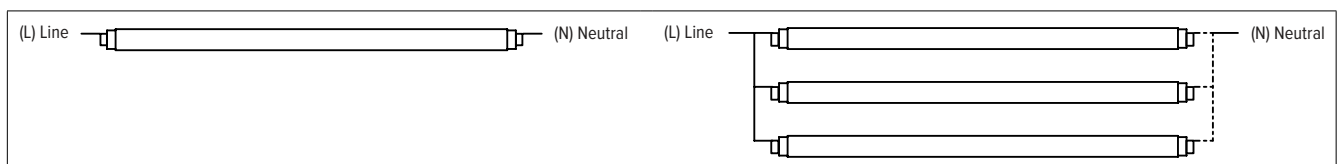

FIG 1.2 Double End Direct Wiring Circuit Diagram For Shunted Lampholders



# TLED LAMPING

## SURFACE & INDUSTRIAL INSTALLATION INSTRUCTIONS

### TYPE C WITH EXTERNAL DRIVER WIRING DIAGRAMS

**FIG 2.1 Double End Installation for Shunted and Non-Shunted Lampholders**

Not polarity sensitive, lamps can be wired at either end.

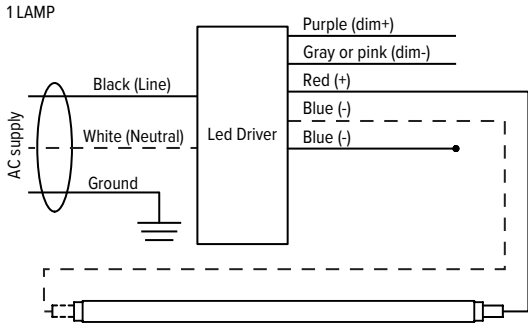

**FIG 2.2 Single End Installation for Non-Shunted Lampholders Only**

Not polarity sensitive, pins can accept '+' or '-'.

