

SURFACE MOUNT & WRAP

INSTALLATION INSTRUCTIONS



WARNING:

- Caution - Risk of Shock. This product must be installed in accordance with the applicable installation code by a person familiar with the construction and operation of the product and the hazards involved.
- Make sure all electrical power is turned off while installing the fixture.
- Warning Risk of Electrical Shock - Verify that supply voltage is correct by comparing it with the luminaire label information.
- This luminaire must be adequately grounded for protection against shock hazards and to assure proper operation.
- Disconnect power before servicing.
- Always use correct lamp type and wattages.

LED PRODUCTS ONLY:

- LEDs are ESD (Electro Static Discharge) sensitive devices that can be easily damaged if the proper ESD mitigating steps are not taken.
- LEDs are very sensitive to mechanical damage. Caution must be taken to avoid damage to the LEDs.
- ESD or mechanical damage voids all warranties.
- Suitable for dry and damp locations.

FOR USE WITH:

- 17
- 18
- 39
- HES

A. BACKVIEWS

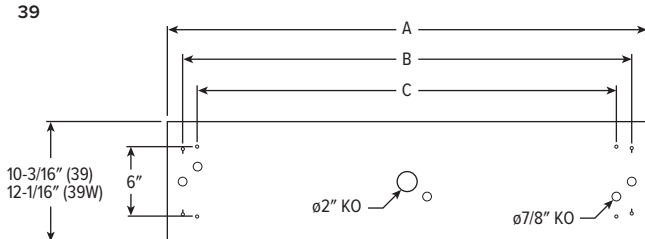
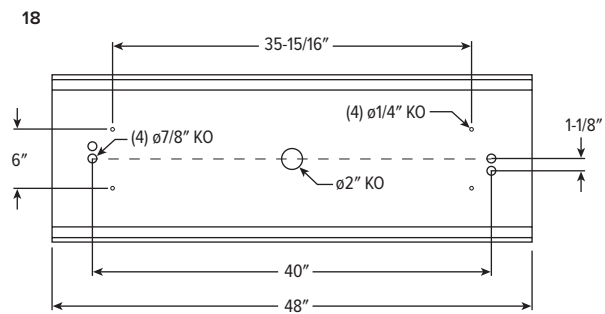
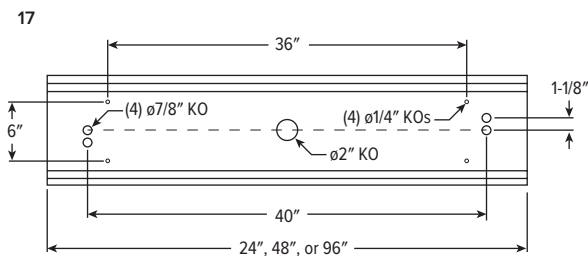

	A (OVERALL)	B (STEM/CABLE O.C.)	C (SURFACE MOUNTING HOLES)
4'	48-1/16"	43"	40"
8'	96-1/16"	91"	88"

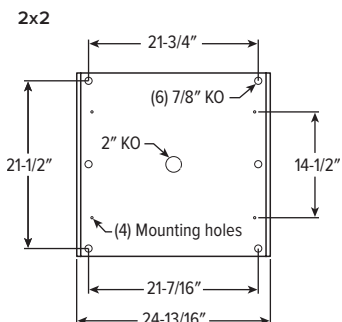
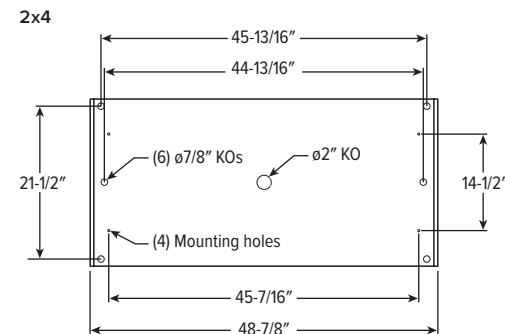
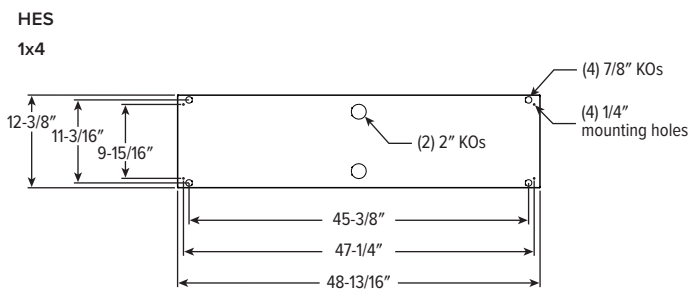

SURFACE MOUNT & WRAP

INSTALLATION INSTRUCTIONS

B. T-BAR CEILING INSTALLATION:

STEP 1: Each Williams wrap around fixture has a center 2" K.O. and 7/8" K.O.'s.

STEP 2: Attach (2) GAT fasteners to the T-bar grid, ensuring they are attached to the "main-T". If the "main-T" is not accessible, make certain the GAT fastener is attached to a rigid member above the ceiling.

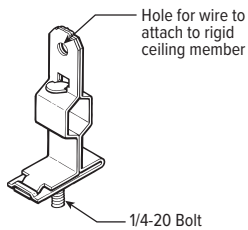

STEP 3: Depending on the placement of the fixture, it may be necessary to drill holes in the back-side of the fixture to match up to the GAT fasteners.

STEP 4: Once the GAT fasteners are lined up with the holes or KO's in the fixture, lift the fixture to the ceiling above. The 1/4-20 bolts of the fastener should be sticking through the holes or KO's. Tighten the nuts to the bolts, attaching the fixture.

STEP 5: Power can be supplied to the fixture using a 7/8" K.O. on the fixture's back – and bringing a piece of "flex" and connector into the fixture – simply plug the connector through the 7/8" K.O. and make electrical connections in the fixture. The 2" center K.O., if supplied, can be used when an outlet box is directly above the fixture K.O.

SHEET ROCK CEILING INSTALLATION:

STEP 1: Locate the ballast/driver inside the fixture.

- A. Some fixtures may require additional disassembly to locate the ballast/driver.
- B. Fixture may have multiple devices (i/e: emergency battery packs) that require additional wiring that must be supplied to the fixture.

STEP 2: Surface mount fixtures typically mount directly over a recessed junction box, by others. Once the ballast/driver is located, remove the appropriate knock out to bring incoming power into the fixture.

STEP 3: On most surface mount fixtures, there are additional knockout locations provided in each corner of the fixture. You can use these locations to adequately support the fixture. Additional hardware required to support the fixture, by others.

STEP 4: Mount the fixture to the ceiling structure, with incoming power pulled into the ballast/driver compartment. Once the fixture is adequately secured to the ceiling, connect incoming power to the ballast/driver leads and replace the wire-way cover. Reassemble fixture if multiple parts are provided.

STEP 5: Wipe off any finger prints and insert the correct lamp (if required) and close the fixture/replace the outer lens.

Make electrical connections in accordance with NEC and local codes.

