

CATALOG #: _____

Type: _____

PROJECT: _____

FEATURES

- Extruded or spun pole shaft with cast aluminum structural base provides durability and resists corrosion
- Choice of straight or tapered smooth aluminum round shafts
- Designed to accommodate up to two fixtures on a pole top assembly with a maximum 36" O.C. fixture span
- 8' to 18' height options
- An assortment of finishes are available to complement the architectural elements of any outdoor space
- Access door provides easy on-site maintenance

SPECIFICATIONS

- SHAFT** – Smooth round pole spun or extruded from 6000 series aluminum alloy.
- POLE TOP** – Plate and tenon provided for top mount luminaire. Removable finial available for poles receiving drilling patterns for side-mount luminaire arm assemblies.
- ACCESS DOOR** – Located on structural base. Grounding provision provided.
- FINISH** – Polyester powder coat bonded to pretreated metal, meets AAMA 2604 specifications for outdoor durability.
- ANCHOR BOLTS** – Conform to ASTM F1554 Grade 55, galvanized a minimum of 12" on the threaded end.
- MOUNTING** – Structural base cast from 356 aluminum alloy. The pole is inserted and welded into the structural base casting. The completed assembly is heat-treated to a T6 temper. A mounting template is provided with each pole and anchor bolt order.

ORDERING EXAMPLE: HHNR - A - 080 - 40 - 40 - 125 - S - TM238 - DBR - AB - OPTIONS

ORDERING INFO

SERIES	MATERIAL	HEIGHT	TOP DIAMETER	SHAFT BASE DIAMETER ⁽¹⁾	WALL THICKNESS
HHNR	A Aluminum	080 8'-0"	Specify according to chart. See page 3 for LOAD AND DIMENSIONAL DATA.		
		100 10'-0"	40 4"	40 4" ⁽⁴⁾	125 0.125"
		120 12'-0"	50 5" ⁽²⁾	50 5"	
		140 14'-0"	60 6" ⁽³⁾	60 6"	
		160 16'-0"			
		180 18'-0"			

SHAPE OF SHAFT ⁽⁵⁾

- S Straight round
- T Tapered round

FIXTURE MOUNTING ⁽⁶⁾

- POLE TOP MOUNT**
- TM238 2-3/8" x 4" Round tenon
- TM278 2-7/8" x 4" Round tenon
- TM3 3" x 4" Round tenon
- TC___ Custom Round Tenon ⁽⁸⁾

DRILLED SIDE MOUNT ⁽⁹⁾

- SM/S Single 0° ⁽¹⁰⁾
- SM/D90 Double 90° ⁽¹¹⁾
- SM/D180 Double 180° ⁽¹²⁾
- SM/T90 Triple 90° ⁽¹³⁾
- SM/T120 Triple 120° ⁽¹⁴⁾
- SM/Q90 Quad 90° ⁽¹⁵⁾

FINISH ⁽⁷⁾

- BLK Black ⁽¹⁶⁾
- DBR Medium bronze
- DBZ Dark bronze
- GRAY Standard gray
- GRN Green ⁽¹⁷⁾
- SLV Satin aluminum ⁽¹⁸⁾
- WHT White ⁽¹⁹⁾
- RAL#___ Specify custom color

ANCHOR BOLTS

- AB Anchor bolts ⁽²⁰⁾
- LAB Less anchor bolts
- PAB Pre-shipped Anchor Bolts ⁽²¹⁾

OPTIONS

- FS Festoon box only ⁽²²⁾

FINIALS ⁽²³⁾

- B Ball
- D Needle
- V Burnsville
- W Woodbridge

NOTES

- Top diameter of the decorative base casting.
- Straight round shaft only.
- Straight round shaft only.
- Straight round shaft only.
- See page 2 for FIXTURE DETAILS.
- Designed for pole top tenon or drilled side mount. See page 2 for MOUNTING DETAILS.
- See page 3 for FINISH OPTIONS.
- Must specify tenon diameter and height, consult factory.
- Removable finial available, see Options.
- Located at 0°.
- Located at 0° and 90°.
- Located at 0° and 180°.
- Located at 0°, 90°, and 180°.
- Located at 0°, 120°, and 240°.
- Located at 0°, 90°, 180°, and 270°.
- RAL #9004.
- RAL #6005.
- RAL #9006.
- RAL #9003.
- Four L-bolts provided with two hex nuts and two flat washers each, shipped with pole.
- Four L-bolts provided with two hex nuts and two flat washers each.
- Casting only. Outlet, cover and hardware by others.
- For poles with side-mount drill only, for additional finial options consult factory. See page 2 for OPTION DETAILS.

FIXTURE DETAILS

SHAPE OF SHAFT

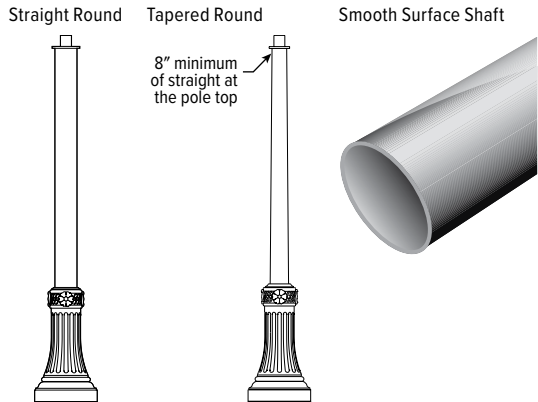

MOUNTING DETAILS

POLE TOP MOUNT TYPICAL TENON

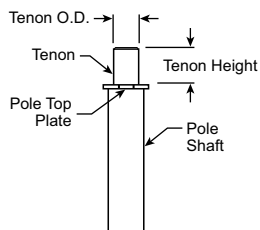

ANCHORAGE DATA

BOLT PROJECTION

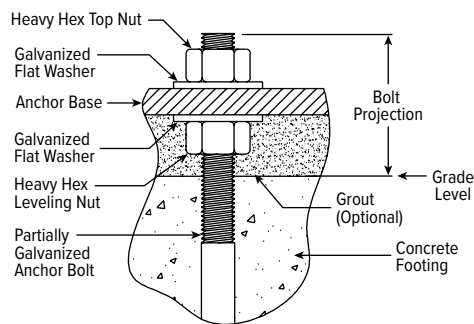

ANCHOR BASE

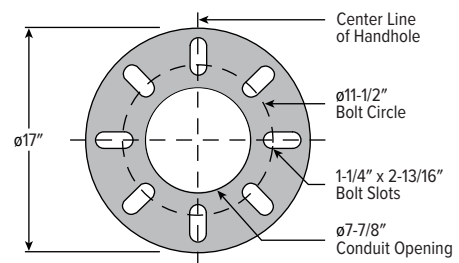

ANCHOR BOLTS			ANCHOR BASE			
BOLT SIZE	PROJECTION	±	BOLT CIRCLE		DIA.	THK.
			DIA.	±		
3/4" x 17" x 3"	3-1/2"	1/4"	11-1/2"	1-1/2"	17"	3/4"

DRILLED SIDE MOUNT OPTIONS

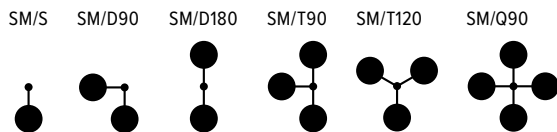

RADIAL INDEX

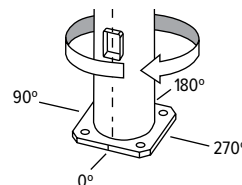
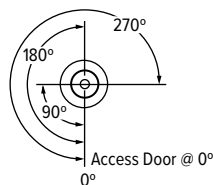

The Radial Index references how parts are oriented around the shaft. A degree measurement is used from a base point. The standard base point of reference is the access door. Degrees are measured in a clockwise motion as viewed from the top of the shaft.

OPTION DETAILS

ALUMINUM FESTOON BOX

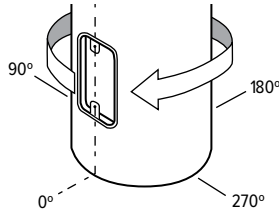

NOTE: The festoon box is located above the access door at 0°.

FINIALS

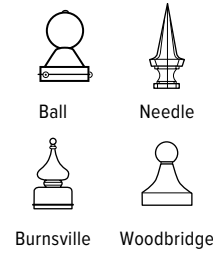

FINISH OPTIONS

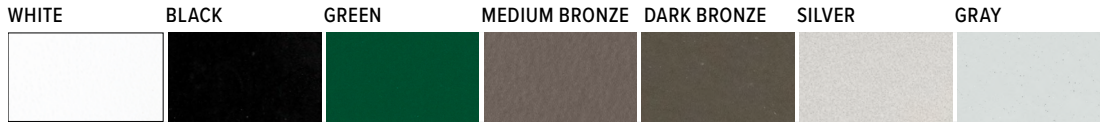

For custom color, please specify RAL code or a manufacturer code with description. All custom colors other than RAL require two sample swatches, minimum 1" square.

LOAD AND DIMENSIONAL DATA

STRAIGHT ROUND

POLE HT. (FT)	CATALOG NUMBER	SHAFT				80 MPH ^{1,2}		90 MPH ^{1,2}		100 MPH ^{1,2}	
		TOP O.D. (IN)	BASE O.D. (IN)	WALL THK. (IN)	STRUC. WT ³ (LBS)	MAX LUMINAIRE EPA (SQ FT)	MAX LUMINAIRE WEIGHT (LBS)	MAX LUMINAIRE EPA (SQ FT)	MAX LUMINAIRE WEIGHT (LBS)	MAX LUMINAIRE EPA (SQ FT)	MAX LUMINAIRE WEIGHT (LBS)
8	HHNR-A-080-40-40-125-S	4	4	0.125	74	12.8	300	10.0	300	8.0	300
	HHNR-A-080-50-50-125-S	5	5	0.125	76	20.0	300	16.5	300	13.3	300
10	HHNR-A-100-40-40-125-S	4	4	0.125	78	9.7	300	7.4	300	5.9	300
	HHNR-A-100-50-50-125-S	5	5	0.125	81	16.3	300	12.8	300	10.3	300
12	HHNR-A-120-40-40-125-S	4	4	0.125	81	7.4	300	5.5	300	4.3	300
	HHNR-A-120-50-50-125-S	5	5	0.125	85	12.9	300	10.1	300	8.1	300
14	HHNR-A-140-50-50-125-S	5	5	0.125	90	10.0	300	7.7	300	6.2	300
16	HHNR-A-160-50-50-125-S	5	5	0.125	94	7.6	300	5.9	300	4.6	300
18	HHNR-A-180-50-50-125-S	5	5	0.125	99	5.8	300	4.4	300	3.4	300
	HHNR-A-180-60-60-125-S	6	6	0.125	104	10.3	300	7.9	300	6.3	300

TAPERED ROUND

POLE HT. (FT)	CATALOG NUMBER	SHAFT				80 MPH ^{1,2}		90 MPH ^{1,2}		100 MPH ^{1,2}	
		TOP O.D. (IN)	BASE O.D. (IN)	WALL THK. (IN)	STRUC. WT ³ (LBS)	MAX LUMINAIRE EPA (SQ FT)	MAX LUMINAIRE WEIGHT (LBS)	MAX LUMINAIRE EPA (SQ FT)	MAX LUMINAIRE WEIGHT (LBS)	MAX LUMINAIRE EPA (SQ FT)	MAX LUMINAIRE WEIGHT (LBS)
8	HHNR-A-080-40-50-125-T	4	5	0.125	75	20.0	300	16.4	300	13.2	300
10	HHNR-A-100-40-50-125-T	4	5	0.125	79	16.3	300	12.7	300	10.2	300
12	HHNR-A-120-40-50-125-T	4	5	0.125	83	12.9	300	10.0	300	7.9	300
	HHNR-A-120-40-60-125-T	4	6	0.125	83	19.8	300	15.4	300	12.4	300
14	HHNR-A-140-40-50-125-T	4	5	0.125	87	10.0	300	7.6	300	6.0	300
	HHNR-A-140-40-60-125-T	4	6	0.125	87	15.8	300	12.2	300	9.7	300
16	HHNR-A-160-40-50-125-T	4	5	0.125	91	7.7	300	5.7	300	4.5	300
	HHNR-A-160-40-60-125-T	4	6	0.125	92	12.6	300	9.6	300	7.7	300
18	HHNR-A-180-40-50-125-T	4	5	0.125	95	5.9	300	4.2	300	3.2	300
	HHNR-A-180-40-60-125-T	4	6	0.125	96	10.1	300	7.6	300	6.0	300

¹ Effective Projected Area (EPA) calculations allow for 1.3 Wind Gust Factor. Maximum EPA and weight values are based on top mounted luminaires or arm assembly having a centroid 2'-6" above and 1'-6" eccentric to the pole top at Nominal Mounting Height. Variations from sizes above are available upon inquiry. Satisfactory performance of poles is dependent upon the pole being properly attached to a supporting foundation of adequate design.

² See page 4 for WIND MAP.

³ Structure Weight is a nominal value which includes the pole shaft and structural base.

▪ Pole installations in various parts of the country perform satisfactorily; however, in select locations destructive vibration can occur. H.E. Williams, Inc. is not responsible for vibration induced fatigue damage.

▪ H.E. Williams, Inc. warrants this product to be free from defects in materials and workmanship. Any defective part returned within one year from the date of delivery of the goods will be repaired or replaced without charge, F.O.B. factory.

▪ This warranty specifically excludes fatigue or similar phenomena resulting from induced vibration, harmonic oscillation or resonance associated with movement of air currents around the product.

▪ The above warranties are given in lieu of all other warranties express or implied, including without limitation, the warranty of merchantability and the warranty of suitability for a particular purpose. It is expressly stated that H.E. Williams, Inc. assumes no liability for consequential or liquidated damages arising out of a breach of the sale, including any warranties arising therefrom, and buyer's remedy shall be limited to repair or replacement of defective parts as described above.

▪ Any action for the breach under a sale including any warranties arising therefrom must be commenced within one year after the cause of action accrues.

WIND MAP

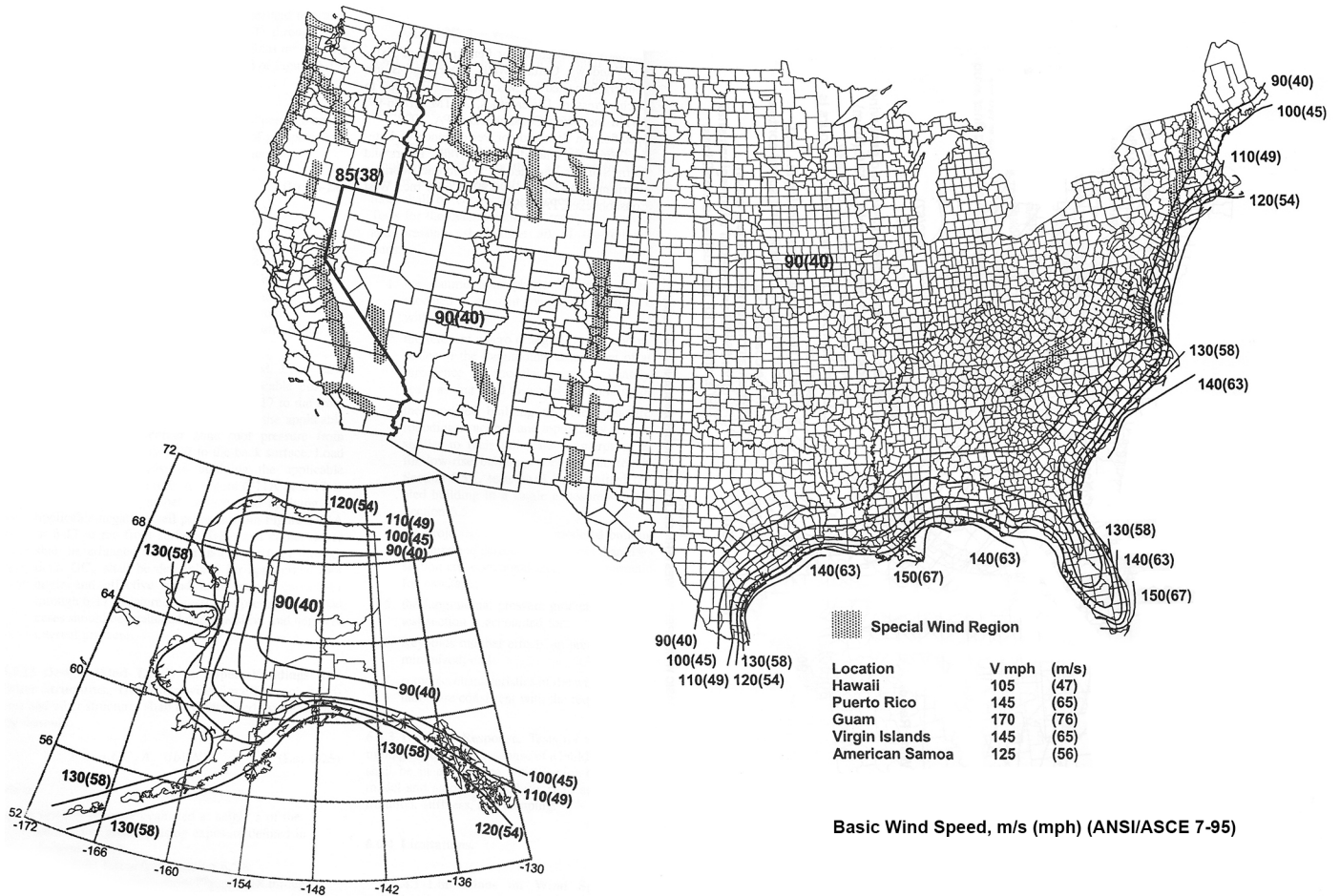

The Effective Projected Area (EPA) standards shown in the Load and Dimensional Data Tables on the specification sheets are designed to withstand dead loads and theoretical dynamic loads developed by variable wind speeds, as charted, with an appropriate wind gust factor under the following conditions:

- Values are nominal design 3-second gust wind speeds in miles per hour (m/s) at 33 ft (10 m) above ground for Exposure C category.

- Linear Interpolation between wind contours is permitted.
- Islands and coastal areas outside the last contour shall use the last wind speed contour of the coastal area.
- Mountainous terrain, gorges, ocean promontories, and special wind regions shall be examined for unusual wind conditions.
- This map is intended as a general guide. Check you local area for unique wind conditions.

From Standard Specifications for Structural Support for Highway Signs, Luminaires, and Traffic Signals, Copyright 2009, by the American Association of State Highway and Transportation Officials, Washington D.C. Used by permission. Documents may be purchased from the AASHTO bookstore at 1-800-231-3475 or online at bookstore.transportation.org